

# KELLY

Gelato and pastry display cabinet

**EUROPROJET**  
PROVOCATEUR DE FROID





**Kelly**  
appeal  
without  
frontiers



# Services

With Kelly you'll store, arrange and display all your products in state-of-the art fashion at any time of day: sweets and pastries, ice cream, cakes and pies, snacks, delicacies, minion appetizers for your happy hour and main courses for lunch or dinner.

Con Kelly conservi, organizzi e presenti a regola d'arte tutti i tuoi prodotti, in ogni momento della giornata: dolci, gelati, torte, pasticceria, snack, gastronomia, sfizioserie per l'happy hour e pietanze per il pranzo o la cena.



**Cold Ventilated**  
Freddo ventilato  
**+1°C / +10°C**

**Cold Ventilated**  
Freddo ventilato  
**+1°C / +10°C**

**Dry hot**  
Vetrina Caldo Secco  
**+65°C**

**Cold Ventilated for Pralines**  
Freddo ventilato per praline  
**+1°C / +10°C**  
**+14°C / +16°C CH**

**Gelato**  
Gelato  
**-16°C / -14°C**

**Cold Ventilated with hot surface**  
Freddo ventilato con piano caldo  
**+4°C / +8°C**  
**+65°C**

**Cold pastry**  
Pasticceria fredda  
**-14°C / -12°C**  
**Stick/Monoportion**  
Stecchi/Monoporzioni  
**-16°C / -14°C**

# Technology

## “Natural” high technology

The refrigeration system is a jewel of high technology and sustainability: refrigeration unit with R290 natural refrigerant, hermetic compressor and off cycle defrosting. Maximum environmental sustainability, because it is fully compatible with European F-GAS legislation.

## Pentane insulation foam

Insulation with the Cyclopentane process, having low environmental impact, guarantees insulation performance that is 20% higher than traditional systems.

## Alta tecnologia “Naturale”

L'impianto di refrigerazione è un gioiello di alta tecnologia e sostenibilità: refrigerante naturale R290 con compressore ermetico e sbrinamento per fermata compressore. Massima sostenibilità ambientale in quanto pienamente compatibile con la normativa europea F-GAS.

## Isolamento con schiuma a pentano

L'isolamento con processo a Ciclopentano a basso impatto ambientale garantisce performance di isolamento superiori del 20% rispetto ai sistemi tradizionali.

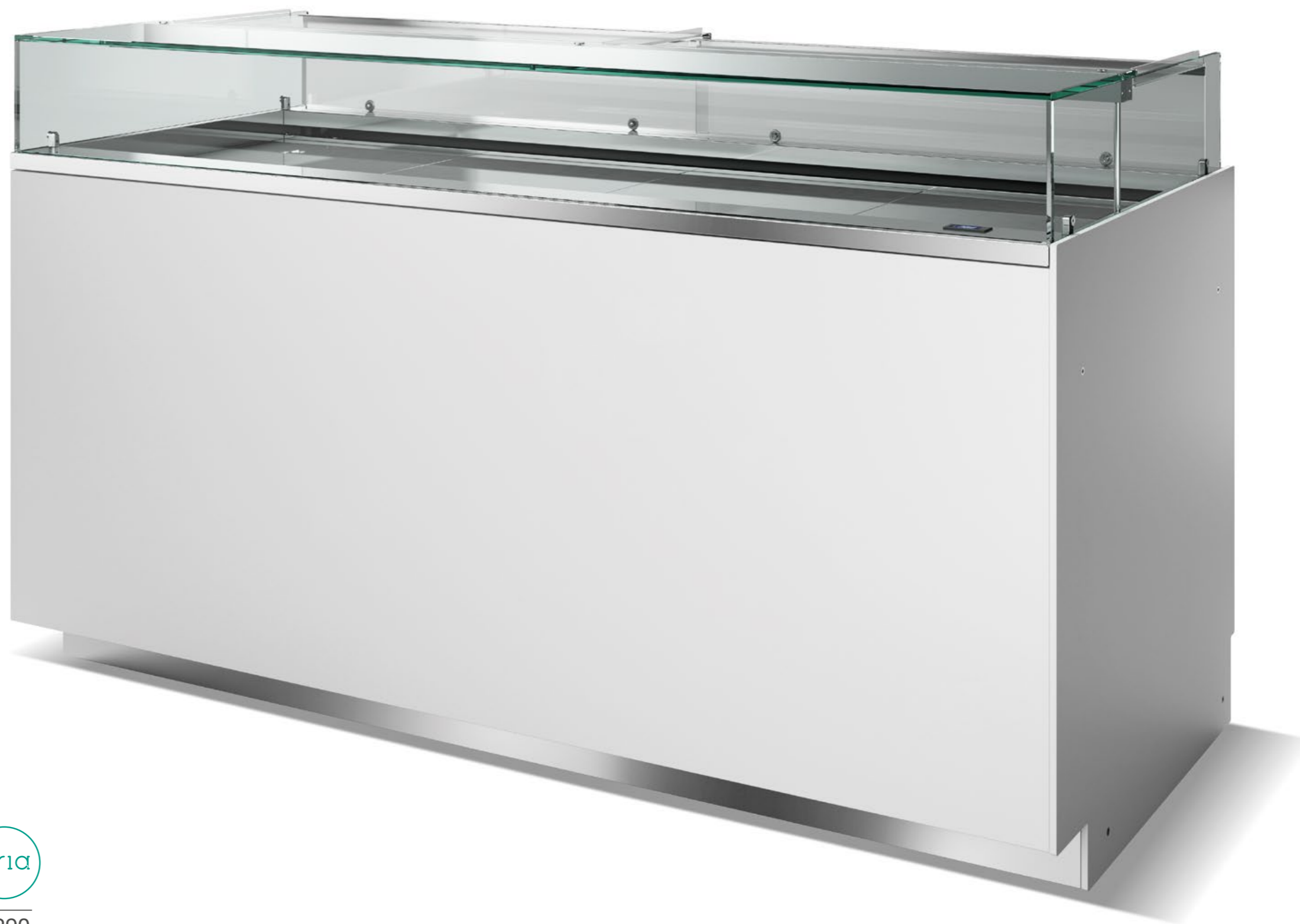

R290

# Kelly in depth

**Extra-light finish tempered glass tower  
with LED lighting**

Castello vetri temperato finitura extrachiario  
con illuminazione a Led

**Closing system  
with sliding elements**

Sistema di chiusura  
con scorrevoli

**Piping between multiple  
elements of the same service**

Canalizzazione tra più elementi  
dello stesso servizio

**Front and Side Panels White  
RAL 9003 or choose from  
a selection of RAL**

Frontale e fianchi RAL 9003  
o RAL a scelta



**Appeal without frontiers:**  
The display decks are flush, with nothing but  
the glass separating the customer from the  
product. No barrier, no disturbing elements:  
for an appealing display.

**Appeal senza barriere:**  
I piani espositivi sono a filo, soltanto il vetro  
separa il cliente dai prodotti. Nessuna barriera,  
nessun elemento di disturbo: per un'esposizione  
di grande appeal.



# Product range



Kelly  
**Angolare**

**H** 117  
**P** 80  
**L** 150 TDX - 150 TSX

Pastry  
Pastry + Hot  
Chocolate



Kelly  
**Lineare**

**H** 117  
**P** 80  
**L** 100-125-150-175-200

Pastry  
Pastry + Hot  
Chocolate



Kelly  
**Gelato**

**H** 117  
**P** 80  
**L** 125

Gelato



Pastry  
Chocolate  
Heated





# KELLY

## Ventilated Chiller

### RV TN +4°C/+8°C

- 3 Configurable positions display top
- Piano espositivo configurabile in 3 altezze

**Display case with ventilated refrigeration and automatic defrost for compressor stop, positive temperature, +4°C/+8°C, ideal for pastry, food & beverages.**

Vetrina a refrigerazione ventilata con sbrinamento automatico per fermata compressore, temperatura positiva nella versione +4°C/+8°C l'ideale per pasticceria, food & beverage.

## Chocolate Chiller

### RV CH +14°C/+16°C

- 3 Configurable positions display top
- Piano espositivo configurabile in 3 altezze

**Display case with ventilated refrigeration and automatic defrost for compressor stop and relative humidity control via probe, positive temperature +14°C/+16°C, ideal for chocolate and pralines.**

Vetrina a refrigerazione ventilata con sbrinamento automatico per fermata compressore e controllo dell'umidità relativa tramite sonda, temperatura positiva +14°C/+16°C, l'ideale per cioccolato e praline.

## Ventilated Chiller / Heated

### RV TN +4°C/+8°C TCS +65°C/+80°C

- **3 Configurable positions heated top**
- Piano espositivo in ceramica antigraffio configurabile in 3 differenti altezze

**Display case with ventilated refrigeration and automatic defrost for compressor stop, positive temperature, +4°C/+8°C, ideal for pastry, food & beverages.**

Vetrina a refrigerazione ventilata con sbrinamento automatico per fermata compressore, temperatura positiva nella versione +4°C/+8°C l'ideale per pasticceria, food & beverage.



#### Relative humidity control

**An additional electronic kit allows to set humidity levels in order to create optimal conditions which preserve chocolate at under 50% of humidity. The perfect display cabinet to preserve quality and taste of your creations.**

#### Controllo dell'umidità relativa

L'aggiunta di un kit elettronico dedicato, permette la regolazione dell'umidità creando le condizioni ottimali per mantenere il cioccolato al di sotto del 50% di umidità relativa. La vetrina perfetta per preservare intatta la qualità e il gusto delle vostre creazioni.

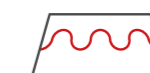

#### Dry heated top

**Kelly TCS has a heated top divided into two parts, made of scratch-proof stratified ceramic with heated glass which can be easily removed for cleaning thanks to the stainless steel handle. The working temperature of the heated top can be adjusted from the electronic control panel up to a maximum of 80°C.**

#### Piano caldo a secco

La versione TCS ospita un piano caldo suddiviso in due parti e realizzato in ceramica antigraffio stratificata con vetro riscaldato, facilmente estraibile per la pulizia grazie alla maniglia in acciaio inox. La temperatura di esercizio sul piano caldo è regolabile tramite centralina elettronica fino ad un massimo di 80°C.



# Kelly Lineare

H 117

P 80

L 100 • 125 • 150 • 175 • 200

Pastry • Chocolate • Snack • Food

## Installation

Plug-in

## Temperature

- +4/+8 °C (TN)
- +14/+16 °C (CH)
- +65 /+80 °C (TCS)

## Refrigerant

R290

## Refrigeration

Ventilated

## Compressor

Hermetic

## Defrost

Off cycle

## Climate class

3

## Front glass

Extra clear single

## Side glass

Extra clear single

## Rear closing system

Glass sliding doors

## Lighting

Led 3000 K

## Base

Height adjustable feet

## Color

White RAL 9003

## Installazione

Plug-in

## Temperatura

- +4/+8 °C (TN)
- +14/+16 °C (CH)
- +65 /+80 °C (TCS)

## Refrigerante

R290

## Refrigerazione

Ventilata

## Compressore

Ermetico

## Sbrinamento

Fermata compressore

## Classe Climatica

3

## Vetro frontale

Singolo extrachiario

## Vetri laterali

Singolo extrachiario

## Chiusura posteriore

Scorrevoli in vetro

## Illuminazione

Led 3000 K

## Basamento

Piedini regolabili in altezza

## Colore

Bianco RAL 9003



R290

## Kelly Lineare

100			125		
RV TN	RV CH	TCS	RV TN	RV CH	TCS

<b>External dimensions (LxDxH)</b> Dimensioni esterne (LxPxH)	H117	1000x819x1170 mm			1250x819x1170 mm		
<b>Capacity (gross/net)</b> Capacità (lorda/netta)	H117	-			-		
<b>Net weight</b> Peso netto	H117	-	-	-	-	-	
<b>Refrigeration</b> Refrigerazione		<b>Ventilated</b> Ventilata			<b>Ventilated</b> Ventilata		
<b>Refrigerant</b> Refrigerante		R290			R290		
<b>Climate class</b> Classe climatica		3					
<b>Operating conditions</b> Condizioni ambientali		25 °C / 60 %RH					
<b>Product temperature</b> Temperatura prodotto		+4/+8 °C	+14/+16 °C	+65/+80 °C	+4/+8 °C	+14/+16 °C	+65/+80 °C
<b>Compressor (q.ty - type)</b> Compressore (q.tà - tipologia)		<b>1 - Hermetic</b> 1 - Ermetico			<b>1 - Hermetic</b> 1 - Ermetico		
<b>Defrost</b> Sbrinamento		<b>Off Cycle</b> Fermata compressore			<b>Off Cycle</b> Fermata compressore		
<b>Power supply</b> Alimentazione		230 V / 1 Ph / 50 Hz					
<b>Electrical input (nominal)</b> Assorbimento elettrico (regime)		411 W / 2,1 A	595 W / 2,7 A	740W / 3,6 A	418 W / 3 A	502 W / 2,7 A	930 W / 04,5 A
<b>Electrical input (defrost)</b> Assorbimento elettrico (sbrinamento)		242 W / 1,3 A			229 W / 1,3 A		-

Technical sheet about models whit condensing unit included with air cooled  
Dati tecnici riferiti a modelli con unità a bordo con condensazione ad aria

## Setup

Allestimento

<b>Bottom shelf (LxD)</b> Ripiano di fondo (LxP)	1000 x 602 mm	1250 x 602 mm
---	---------------	---------------

150			175			200		
RV TN	RV CH	TCS	RV TN	RV CH	TCS	RV TN	RV CH	TCS

1500x819x1170 mm			1750x819x1170 mm			2000x819x1170 mm		
-			-			-		
-	-	-	-	-	-	-	-	-
<b>Ventilated</b> Ventilata			<b>Ventilated</b> Ventilata			<b>Ventilated</b> Ventilata		
R290			R290			R290		
3								
25 °C / 60 %RH								
+4/+8 °C	+14/+16 °C	+65/+80 °C	+4/+8 °C	+14/+16 °C	+65/+80 °C	+4/+8 °C	+14/+16 °C	+65/+80 °C
<b>1 - Hermetic</b> 1 - Ermetico			<b>1 - Hermetic</b> 1 - Ermetico			<b>1 - Hermetic</b> 1 - Ermetico		
<b>Off Cycle</b> Fermata compressore			<b>Off Cycle</b> Fermata compressore			<b>Off Cycle</b> Fermata compressore		
230 V / 1 Ph / 50 Hz								
498 W / 3 A	597 W / 3,2 A	1120 W / 5,4 A	504 W / 3,6 A	603 W / 3,3 A	1320 W / 6,4 A	567 W / 4,1 A	788 W / 4,3 A	1500 W / 7,2 A
307 W / 1,6 A		-	313 W / 1,7 A		-	450 W / 2,4 A		-

1500 x 602 mm	1750 x 602 mm	2000 x 602 mm
---------------	---------------	---------------

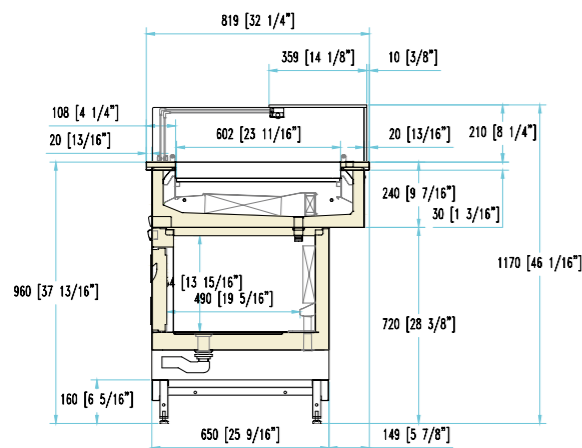

## Available colours - Colori disponibili

Front panel (1) - Side panels (2)  
Pannello frontale (1) - Fianchi laterali (2)

-  RAL 9003
-  RAL on demand
- **Standard / Di serie**



# Kelly Angolare

H 117  
P 80  
L 150 TDX • 150 TSX

Pastry • Chocolate • Snack • Food

<p><b>Installation</b> Plug-in</p> <p><b>Temperature</b> • +4/+8 °C (TN) • +14/+16 °C (CH) • +65 /+80 °C (TCS)</p> <p><b>Refrigerant</b> R290</p> <p><b>Refrigeration</b> Ventilata</p> <p><b>Compressor</b> Hermetic</p> <p><b>Defrost</b> Off cycle</p>	<p><b>Climate class</b> 3</p> <p><b>Front glass</b> Extra clear single</p> <p><b>Side glass</b> Extra clear single</p> <p><b>Rear closing system</b> Glass sliding doors</p> <p><b>Lighting</b> Led 3000 K</p> <p><b>Base</b> Heigh adjustable feet</p> <p><b>Color</b> White RAL 9003</p>	<p><b>Installazione</b> Plug-in</p> <p><b>Temperatura</b> • +4/+8 °C (TN) • +14/+16 °C (CH) • +65 /+80 °C (TCS)</p> <p><b>Refrigerante</b> R290</p> <p><b>Refrigerazione</b> Ventilata</p> <p><b>Compressore</b> Ermetico</p> <p><b>Sbrinamento</b> Fermata compressore</p>	<p><b>Classe Climatica</b> 3</p> <p><b>Vetro frontale</b> Singolo extrachiaro</p> <p><b>Vetri laterali</b> Singolo extrachiaro</p> <p><b>Chiusura posteriore</b> Scorrevoli in vetro</p> <p><b>Illuminazione</b> Led 3000 K</p> <p><b>Basamento</b> Piedini regolabili in altezza</p> <p><b>Colore</b> Bianco RAL 9003</p>
---	--	---	--



aria  
R290

## Kelly Angolare

	TDX			TSX		
	RV TN	RV CH	RV TN / TCS	RV TN	RV CH	RV TN / TCS
<b>External dimensions (LxDxH)</b> Dimensioni esterne (LxPxH)	H117 1500x819x1170 mm			H117 1500x819x1170 mm		
<b>Capacity (gross/net)</b> Capacità (lorda/netta)	H117 -			H117 -		
<b>Net weight</b> Peso netto	H117 210 kg			H117 215 kg		
<b>Refrigeration</b> Refrigerazione	Ventilated Ventilata			Ventilated Ventilata		
<b>Refrigerant</b> Refrigerante	R290			R290		
<b>Climate class</b> Classe climatica	3					
<b>Operating conditions</b> Condizioni ambientali	25 °C / 60 %RH					
<b>Product temperature</b> Temperatura prodotto	+4/+8 °C	+14/+16 °C	+65/+80 °C	+4/+8 °C	+14/+16 °C	+65/+80 °C
<b>Compressor (q.ty - type)</b> Compressore (q.tà - tipologia)	1 - Hermetic 1 - Ermetico		-	1 - Hermetic 1 - Ermetico		-
<b>Defrost</b> Sbrinamento	Off Cycle Fermata compressore		-	Off Cycle Fermata compressore		-
<b>Power supply</b> Alimentazione	230 V / 1 Ph / 50 Hz					
<b>Electrical input (nominal)</b> Assorbimento elettrico (regime)	418 W / 3 A	502 W / 2,7 A	930 W / 04,5 A	418 W / 3 A	502 W / 2,7 A	930 W / 04,5 A
<b>Electrical input (defrost)</b> Assorbimento elettrico (sbrinamento)	229 W / 1,3 A		-	229 W / 1,3 A		-

Technical sheet about models whit condensing unit included with air cooled  
Dati tecnici riferiti a modelli con unità a bordo con condensazione ad aria

### Setup Allestimento

<b>Bottom shelf (LxD)</b> Ripiano di fondo (LxP)	1400 x 602 mm	1400 x 602 mm
---	---------------	---------------



# Gelato





# Kelly Gelato

H 117  
P 80  
L 125

## Gelato

### Installation

Plug-in

### Dual Zone

-20/+2 °C  
(max. 10 °C difference between right and left side)

### Refrigerant

R290

### Refrigeration

Side ventilation (Patented)

### Defrost

Hot Gas

### Climate class

4

### Upper glass

Single heated

### Front glass

Single heated

### Side glass

Heated laminated

### Rear closing

Plexiglass sliding lids

### Service top

Stainless steel

### Lighting

Led 3000 K

### Night mode

Night closing system. Allows the gelato to be perfectly preserved by interrupting the defrost cycle.

### Equipment handling

Height-adjustable feet

### Installazione

Plug-in

### Dual Zone

-20/+2 °C  
(max 10 °C di differenza tra la parte destra e la parte sinistra della vasca)

### Refrigerante

R290

### Refrigerazione

Ventilazione laterale (Patented)

### Sbrinamento

Gas caldo

### Classe climatica

4

### Vetro superiore

Singolo riscaldato

### Vetro frontale

Singolo riscaldato

### Vetri laterali

Stratificati riscaldati

### Chiusura posteriore

Scorrevoli in plexiglas

### Piano di servizio

Acciaio inox

### Illuminazione

Led 3000 K

### Night mode

Sistema di chiusura notturna. Permette di conservare il gelato perfettamente grazie all'interruzione del ciclo di sbrinamento.

### Movimentazione

Piedini regolabili in altezza



## Kelly Gelato

125

### External dimensions (LxDxH)

Dimensioni esterne (LxPxH)

1250 x 819 x 1170 mm

### Capacity (gross/net)

Capacità (lorda/netta)

180 / 130 lt

### Net weight

Peso netto

150 kg

### Refrigeration

Refrigerazione

Ventilated - Ventilata

### Refrigerant

Refrigerante

R290 (Plug-in)

### Climate class

Classe climatica

4

### Operating conditions

Condizioni ambientali

30 °C / 55 %RH

### Temperature range

Temperatura di regolazione

-20/+2 °C

### Product temperature

Temperatura prodotto

-16/-14 °C

### Compressor (type)

Compressore (tipologia)

2 Hermetic - 2 Ermetici

### Defrost

Sbrinamento

Hot gas - Gas caldo

### Power supply

Alimentazione

230 V / 1 Ph / 50 Hz

### Electrical input (nominal)

Assorbimento elettrico (regime)

1350 W / 7,4 A

### Electrical input (defrost)

Assorbimento elettrico (sbrinamento)

1240 W / 6,6 A

Technical sheet about models with condensing unit included with air cooled  
Dati tecnici riferiti a modelli con unità a bordo con condensazione ad aria.

### Setup

Allestimento

#### 5 Lt

360x165x120hx150h



12 (6+6)

#### 5 Lt

360x250x80hx120hx150h



8 (4+4)

#### Tray

Vassoio



4 (2+2)

#### Ice cream stick container

Vaschetta stecchi



8 (4+4)

#### Single portions container

Vaschetta monoporzioni



8 (4+4)

