



Collection  
2022

Z•IN



**TOUS LES COMPTOIRS TRADITIONNELS**

# PORTHOS



Width in cm.

109



Length in cm.

150 · 200  
250 · 300



Climate class

3 M2  
25°C / u.r. 60%

## Stile, efficienza e qualità costruttiva.

Lo stile modernamente curato e l'ampia gamma di versioni, accessori e possibilità di personalizzazioni lo rendono ideale per soddisfare ogni esigenza e ogni layout nei concept stores più alla moda.



### Style, efficiency and quality of design.

With its search for modern design and wide range of versions, accessories and customization options, it is perfect to suit all the needs and layouts of modern concept stores.

### Style, efficacité et qualité de construction.

Grâce à son style très actuel et à sa vaste gamme de versions, d'accessoires et de possibilités de personnalisation, il devient idéal pour satisfaire toutes les exigences et tous les concepts stores les plus branchés.

### Stil, Effizienz und Verarbeitungsqualität.

Der moderne Stil und die große Vielfalt an Ausführungen, Zubehör und Anpassungsmöglichkeiten erlauben es, jeder Anforderung und jedem Layout in den angesagtesten Concept Stores gerecht zu werden.

D137 Urban Wood  
Version  
PL-1 / AA 90° / PC-5



# PORTHOS

White Oak  
Version  
PL-1 / AA 90° / PC-5 **D136**



1

Vetri apribili verso l'alto.

Lift up glass structure.

Structure avec verre s'ouvrant vers le haut.

Hebenverglasung Struktur.

2

Robusta struttura in alluminio

Solid aluminium structure.

Structure robuste en aluminium.

Stabile Aluminium-Struktur.

3

Illuminazione LED.

LED lighting.

Éclairage LED

LED-Beleuchtung

4

Zona esposizione in acciaio Inox.

Display area in stainless steel.

Zone d'exposition en acier inox.

Auslagefläche aus Edelstahl.

5

Piano lavoro standard in acciaio Inox.

Standard working plate in stainless steel.

Plan de travail standard en acier inox.

Standard Arbeitsplatte aus Edelstahl.

D107

Splendido  
Azzurro  
PL-2 / Terminal Cash / PF-2



Merce facile da posizionare con vetri frontali apribili.

The glass opens from the front to facilitate the display of goods.

Marchandise facile à exposer avec vitres frontales ouvrables.

Leicht zu positionierende Waren dank aufklappbarer Frontfenster.



Versione PC5 – Riscaldamento Bagno Maria

Version PC5 – Bain Marie warming method.

Version PC5 – Chauffage au bain-marie.

Version PC5 – Warmhalten im Wasserbad.

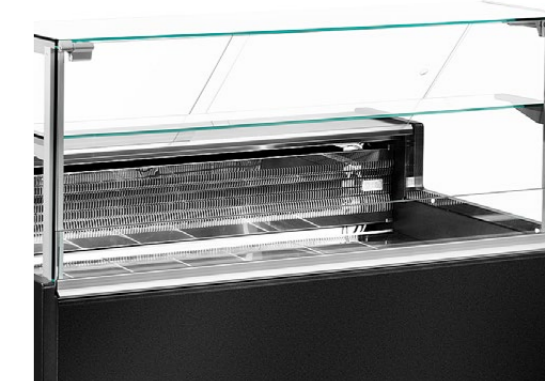

Vetro intermedio (optional con illuminazione a LED).

Intermediate glass (optional LED lighting).

Vitre intermédiaire (option avec éclairage à LED).

Zwischenregal aus Glas (optional mit LED-Beleuchtung).



## PORTHOS Versions

Gray Black Optional

Colori spalla  
End colours  
Couleurs des côtés  
Farben für Rückwände

PL-1

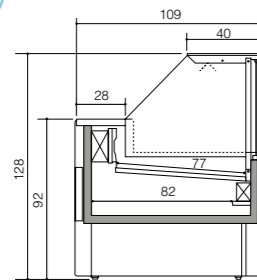

Statico con cella  
Static with cool storage  
Statique avec réserve  
Statisch mit Unterbaukuehlung

PL-2

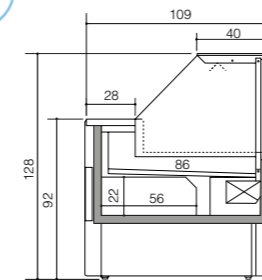

Ventilato con cella  
Ventilated with cool storage  
Ventiléé avec réserve  
Umluft mit Unterbaukuehlung

PO-3

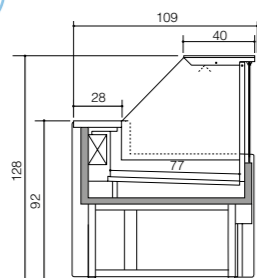

Statico senza cella  
Static without cool storage  
Statique sans réserve  
Statisch ohne Unterbaukuehlung

PO-4

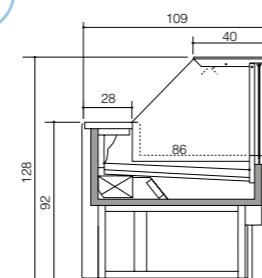

Ventilato senza cella  
Ventilated without cool storage  
Ventiléé sans réserve  
Umluft ohne Unterbaukuehlung

PC-5

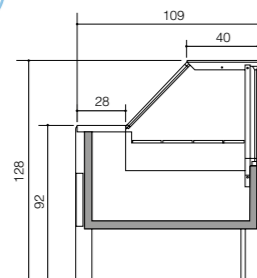

Riscaldamento - Bagnomaria  
Heating - Bain Marie  
Chauffage - Bain-Marie  
Heisse Theke - Bain-Marie

PF-2

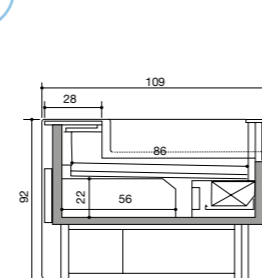

Self Service

Ventilato con cella  
Ventilated with cool storage  
Ventiléé avec réserve  
Umluft mit Unterbaukuehlung

# Cold? Hot? Well, both.



ZOIN





Width in cm.

98



Length in cm.

150 · 200  
250 · 300  
350 · 400



Climate class

3 M2  
25°C / u.r. 60%

## L'espositore alla moda per i locali più trendy.

Perfetto per creare ambienti di vendita dal gusto contemporaneo e internazionale, Mesetas si distingue per gli alti contenuti tecnici e per il design di successo. È particolarmente adatto agli ambienti in cui è necessario massimizzare lo spazio espositivo.

### A trendy display counter for trendy stores.

Perfect to add a contemporary and international touch, Mesetas stands out for its successful design and high technological content. Specifically indicated where the display area needs to be maximised.

### Le présentoir à la mode pour les commerces les plus branchés.

Parfait pour créer des espaces de vente au style contemporain et international, Mesetas est caractérisé par ses contenus techniques élevés et son design très apprécié. Il s'adapte particulièrement aux espaces dans lesquels il est primordial de maximiser la surface d'exposition.

### Der modische Aussteller für die trendigsten Locations.

Mesetas eignet sich perfekt für die Kreation von Verkaufswelten mit einem zeitgemäßen und internationalen Geschmack. Es zeichnet sich durch einen hohen technischen Gehalt und ein gelungenes Design aus und eignet sich ganz besonders für Bereiche, in denen der Ausstellraum maximal ausgeschöpft werden soll.

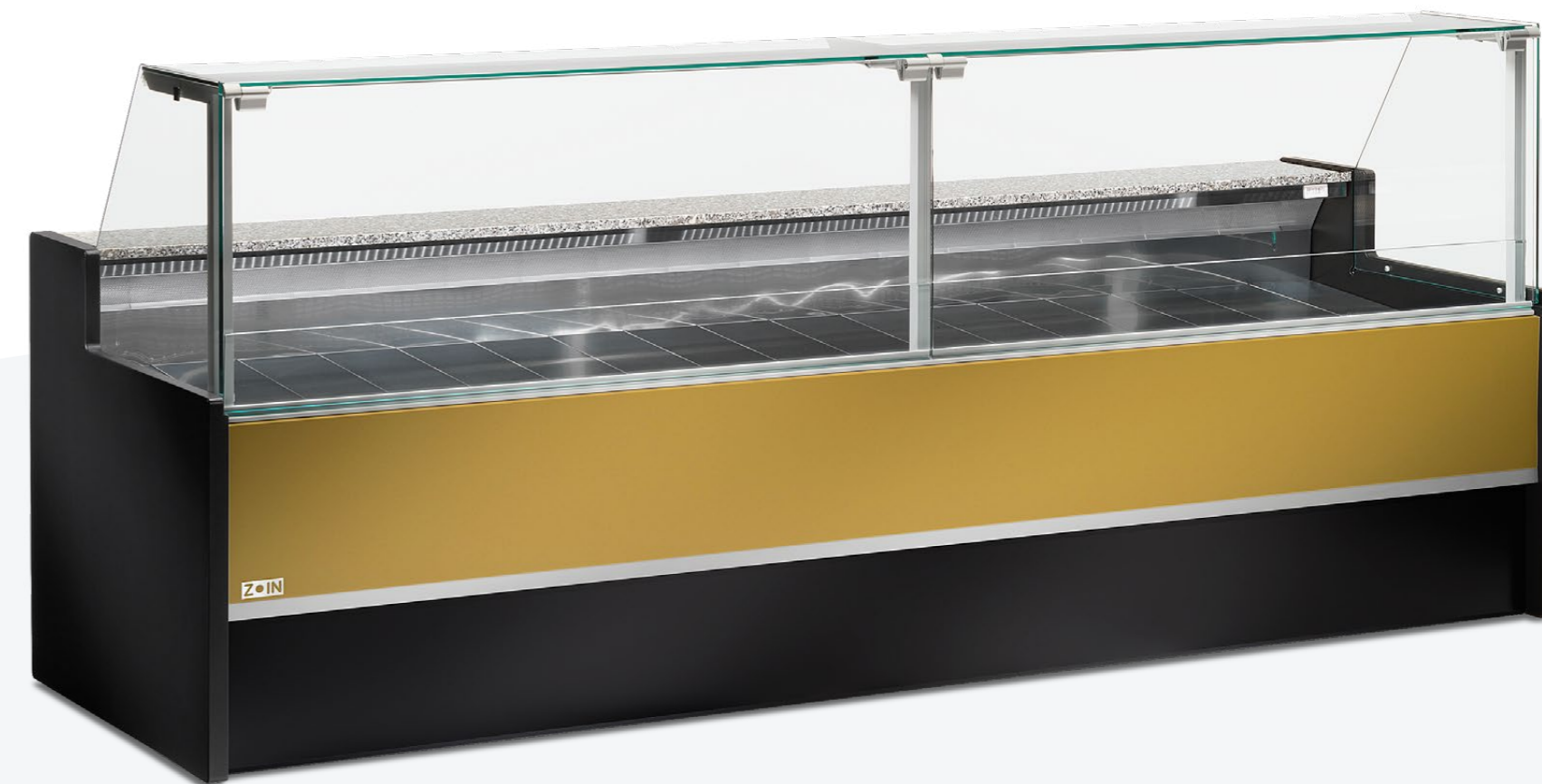

D153 Magic Gold Version D-2

# MESETAS



1

Vetri apribili verso l'alto.

Lift up glass structure.

Structure avec verre s'ouvrant vers le haut.

Hebenverglasung Struktur.

2

Robusta struttura in alluminio.

Solid aluminium structure.

Structure robuste en aluminium.

Stabile Aluminium-Struktur.

3

Zona esposizione in acciaio Inox.

Display area in stainless steel.

Zone d'exposition en acier inox.

Auslagefläche aus Edelstahl.

4

Piano lavoro in granito (Rosa Beta).

Working plate in granit (Rosa Beta).

Plan de travail en granit (Rosa Beta).

Arbeitsplatte aus (Rosa Beta).

Tortora  
Version  
D-2 D152

I301  
Scotch Brite  
Version  
C-2

White Oak  
Version  
C-2 D136



Merce facile da posizionare con vetri frontali apribili.

The glass opens from the front to facilitate the display of goods.

Marchandise facile à exposer, grâce aux vitres frontales ouvrables.

Leicht zu positionierende Waren dank aufklappbarer Frontfenster.



Massima trasparenza.

Maximum transparency.

Transparence maximum.

Maximale Transparenz.



D2 Versione ventilata.

D2 ventilated version.

D2 Version ventilée.

D2 Belüftete Ausführung.



## MESETAS Versions

Gray Black Optional

Colori spalla  
End colours  
Couleurs des côtés  
Farben für Rückwände

C-1

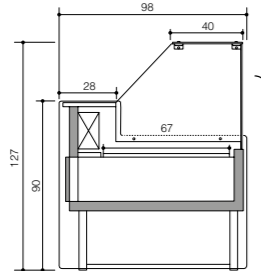

Vetri apribili a compasso -  
Statico con cella

Glass with hinged opening -  
Static with cool storage

Statique avec réserve -  
Vitres relevables

Fenster mit Kompassöffnung -  
Statisch mit Unterbaukuehlung

C-2

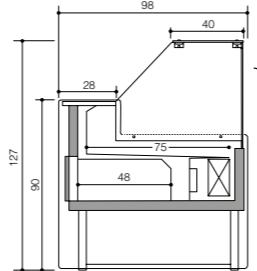

Vetri apribili a compasso -  
Ventilato con cella

Glass with hinged opening -  
Ventilated with cool storage

Ventiléé avec réserve -  
Vitres relevables

Fenster mit Kompassöffnung -  
Umluft mit Unterbaukuehlung

D-1

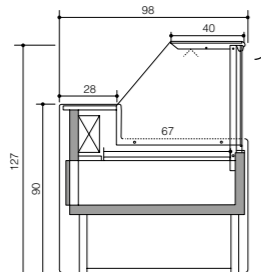

Vetri apribili verso l'alto -  
Statico con cella

Lift up glass structure -  
Static with cool storage

Structure avec verre s'ouvrant  
vers le haut - Statique avec réserve

Hebenverglasung Struktur -  
Statisch mit Unterbaukuehlung

D-2

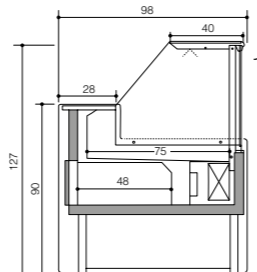

Vetri apribili verso l'alto -  
Ventilato con cella

Lift up glass structure -  
Ventilated with cool storage

Structure avec verre s'ouvrant  
vers le haut - Ventiléé avec réserve

Hebenverglasung Struktur -  
Umluft mit Unterbaukuehlung

Now, that's  
a trendy counter!



ZOIN



# ORLEANS



Width in cm.

81



Length in cm.

100 · 150  
200 · 250



Climate class

3 M2  
25°C / u.r. 60%

**Un espositore dal design curato e attuale, da personalizzare per allinearlo allo stile del punto vendita.**

Orleans è particolarmente indicato per pasticceria, pane, gastronomia, sandwich e in generale per negozi di piccole dimensioni: grazie alla sua larghezza di 81 cm può essere inserito in ambienti dallo spazio ridotto.

**The search for contemporary design is what distinguishes this display, which can be customised according to the style of the store.**

Orleans is specifically designed for pastry products, bread, gastronomy, sandwiches and for small stores. With a width of 81 cm it can fit tiny surfaces perfectly.

**Un présentoir au design soigné et actuel, à personnaliser pour le coordonner au style du point de vente.**

Orleans est particulièrement indiqué pour les pâtisseries, les pains, les plats préparés, les sandwiches et, en général, pour les magasins de petites dimensions: grâce à sa largeur de 81 cm, il peut être inséré dans des espaces réduits.

**Ein Aussteller mit einem präzisen und aktuellen Design, das an den Stil der Verkaufsstelle angepasst werden kann.**

Orleans eignet sich besonders für Süßwaren, Brot, Gastronomie, Sandwiches und im Allgemeinen für kleine Läden: dank seiner Breite von 81 cm kann es auch in kleineren Räumen aufgestellt werden.



**D97** Black Version C-1



# ORLEANS



1

Vetro intermedio con illuminazione.  
Intermediate shelf with lighting.  
Vitre intermédiaire avec éclairage.  
Zwischenglaselage mit Beleuchtung.

2

Cappello in vetro.  
Upper glass.  
Chapeau en verre.  
Zahlplatte aus Glas.

3

Struttura con vetro fisso.  
Structure with fixed glass.  
Structure avec verre fixe.  
Struktur mit festen Glas.

4

Illuminazione LED.  
LED lighting.  
Éclairage LED  
LED-Beleuchtung

5

Zona esposizione in acciaio Inox.  
Display area in stainless steel.  
Zone d'exposition en acier inox.  
Auslagefläche aus Edelstahl.

White  
Version  
C-1

D110

## ORLEANS Versions

Gray Black Optional

Colori spalla  
End colours  
Couleurs des côtés  
Farben für Rückwände



Esposizione e illuminazione ottimali con i ripiani intermedi in vetro.  
Optimal display and lighting thanks to its intermediate glass shelves.  
Exposition et éclairage optimaux avec des étagères intermédiaires en verre  
Optimale Präsentation und Beleuchtung mit den Zwischenregalen aus Glas



Piano di lavoro in granito (Rosa Beta) – Optional Nero assoluto.  
Granite worktop (Rosa Beta) – Optional Absolute Black.  
Plan de travail en granit (Rosa Beta) – En option, Noir absolu.  
Granit-Arbeitsplatte (Rosa Beta) – Optional tiefschwarz.



Esposizione ideale per i vostri piatti di gastronomia.  
Ideal for displaying gastronomic dishes.  
Exposition idéale pour vos plats préparés.  
Idealer Aussteller für Ihre kulinarischen Kreationen.

C-1

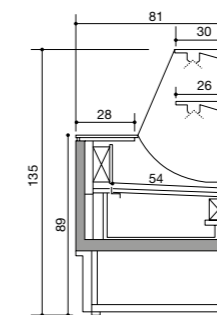

Statico con cella  
Static with cool storage  
Statique avec réserve  
Statisch mit Unterbaukuehlung

C-3

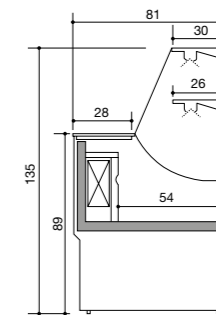

Statico senza cella  
Static without cool storage  
Statique sans réserve  
Statisch ohne Unterbaukuehlung

C-5

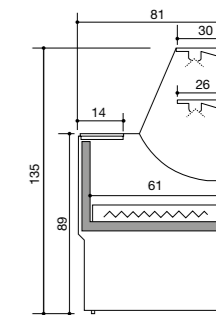

Versione calda (60°C)  
Hot Version (60°C)  
Version chaude (60°C)  
Warme Ausfuerung (60°)

# KRISTALL



Width in cm.

78



Length in cm.

100 · 120  
150



Climate class

3 M1  
25°C / u.r. 60%

## Carisma e stile per una visibilità al top.

Kristall è l'espositore perfetto per la vendita di prodotti di qualità, in grado di offrire loro tutta la visibilità che meritano. È ideale per prodotti gastronomici, pasticceria e dolci, sandwich o piatti pronti.

### Charisma and style for utmost visibility.

Kristall is perfect for enhancing high quality products, offering them all the visibility they deserve. Ideal for gastronomic products, pastry creations and cakes, sandwiches or ready meals.

### Charisme et style pour une meilleure visibilité.

Kristall est le présentoir parfait pour la vente de produits de qualité, il est en mesure de leur offrir toute la visibilité qu'ils méritent. Il est parfait pour les produits préparés, les pâtisseries, les sandwiches ou les plats à emporter.

### Charisma und Stil für höchste Sichtbarkeit.

Kristall ist die perfekte Auslage für den Verkauf von Qualitätsprodukten, die gebührend in Szene gesetzt werden sollen. Es eignet sich hervorragend für gastronomische Produkte, Gebäck und Kuchen, Sandwiches oder Fertiggerichte.



D97 Black Version C-4



# KRISTALL

White Oak  
Version  
C-4

D136

D110

White  
Version  
C-4



1

Vetri Thermopane con serigrafia in nero.

Thermopane glasses with black serigraphy.

Vitres Thermopane sérigraphies noir.

Thermopane-Verglasungen mit schwarz Serigraphie.

2

Illuminazione verticale a LED.

LED lighting.

Éclairage LED

LED-Beleuchtung

3

Zona esposizione verniciata nero.

Display area black painted.

Zone d'exposition peint en noir.

Auslagefläche schwarz lackiert.

4

Ripiani in vetro refrigerati.

Refrigerated glass shelves.

Étagères en verre réfrigérées.

Gekühlte Glasregale.

5

Porte scorrevoli posteriori in Thermopane.

Rear sliding doors in Thermopane glass.

Portes coulissantes arrières en Thermopane.

Hintere Glasschiebetüren aus Thermopan





**KRISTALL**  
Versions



Gray **Black** Optional

Colori spalla  
End colours  
Couleurs des côtés  
Farben für Rückwände

C-4

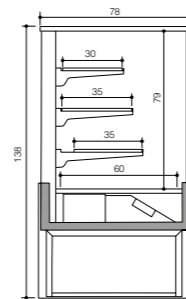

Ventilato senza cella  
Ventilated without cool storage  
Ventiléé sans réserve  
Umluft ohne Unterbaukuehlung

C-5

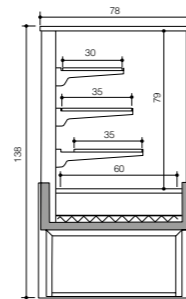

Versione calda (60°C)  
Hot Version (60°C)  
Version chaude (60°C)  
Warme Ausfuerung (60°)

C-6

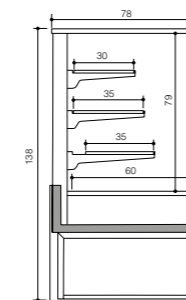

Non refrigerato  
Not refrigerated cabinet  
Sans réfrigération  
Nicht gekühlte Theke

You sure can  
see it all!



Z•IN





Width in cm.

91



Length in cm.

100 · 150  
200 · 250  
300



Climate class

3 M2  
25°C / u.r. 60%

## Studiato per attirare l'attenzione.

Patagonia è il modello di banco refrigerato ideale per attrarre i clienti: una vetrina perfetta per l'esposizione di prodotti di gastronomia, sandwich e piatti ready-to-eat. È disponibile con il vetro retto oppure con il vetro curvo.

### Design to catch attention.

A refrigerated counter to attract consumers' attention: the perfect counter to display gastronomic products, sandwiches and ready meals. Available with straight or curved glass.

### Conçu pour attirer l'attention.

Patagonia est le modèle de comptoir réfrigéré idéal pour attirer les clients: une vitrine parfaite pour l'exposition de produits préparés, de sandwiches et de plats à emporter. Il est disponible avec une vitrine droite ou bien bombée.

### Als Blickfang entwickelt.

Patagonia ist das ideale Kühltheckenmodell, um den Blick der Kunden auf sich zu ziehen: eine perfekte Vitrine für die Präsentation von Feinkostprodukten, Sandwiches und verzehrfertigen Gerichten. Es ist mit geradem oder gebogenem Glas erhältlich.

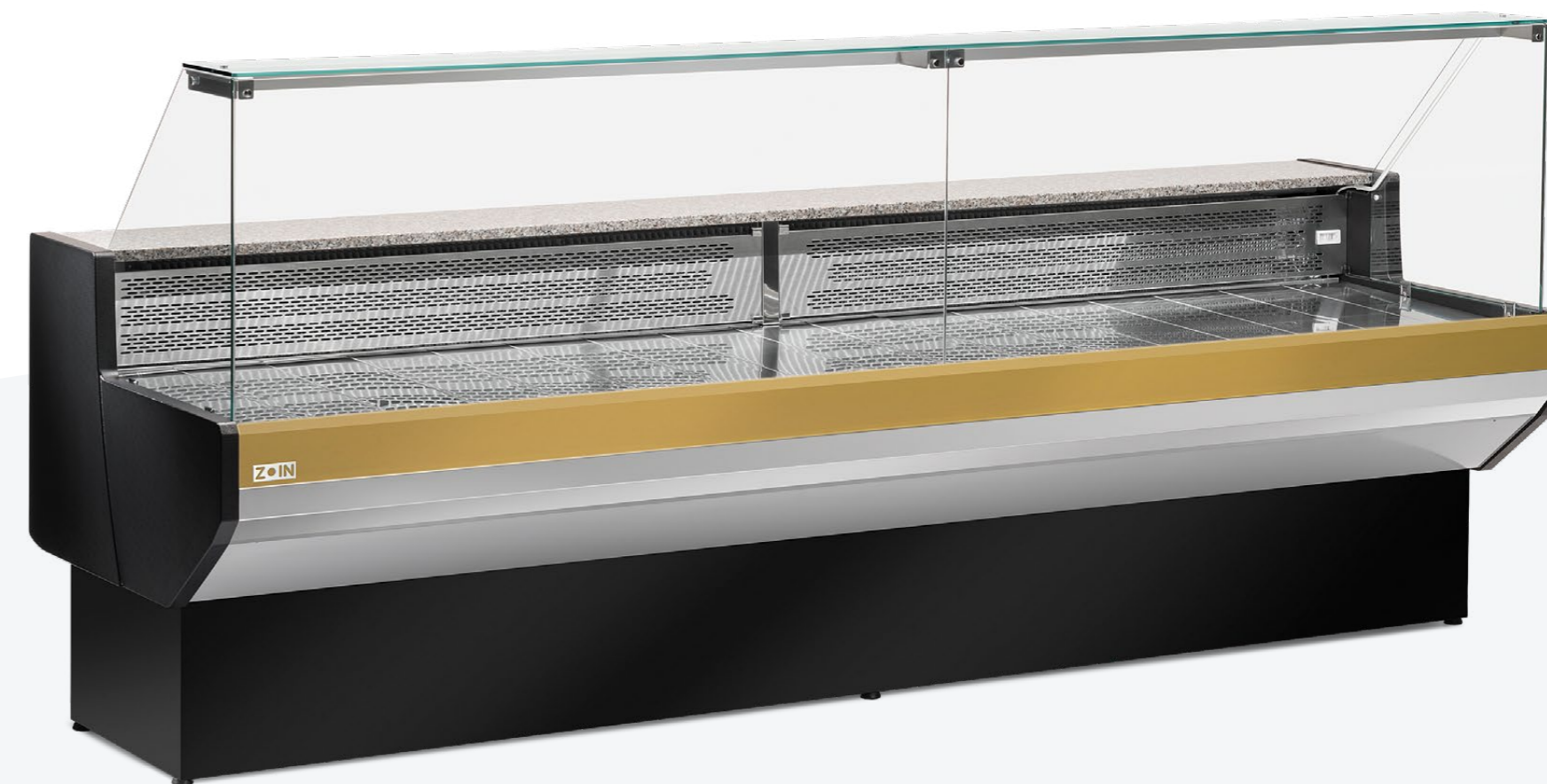

D153 Magic Gold Version C-1

# PATAGONIA



1

Struttura cappello in vetro curvo temperato.

Cap in curved tempered glass.

Structure plafond avec vitrine bombée en verre trempé.

Haubenstruktur aus gebogenem, gehärtetem Glas.

2

Illuminazione LED.

LED lighting.

Éclairage LED

LED-Beleuchtung

3

Zona esposizione in acciaio Inox.

Display area in stainless steel.

Zone d'exposition en acier inox.

Auslagefläche aus Edelstahl.

4

Piano lavoro in granito (Rosa Beta).

Working plate in granit (Rosa Beta).

Plan de travail en granit (Rosa Beta).

Arbeitsplatte aus (Rosa Beta).

Splendido  
Azzurro  
Y-2 D107

D97 Black  
Version Y-2



White Butter  
Version C-1 D151



D153 Magic Gold

Urban Wood D137

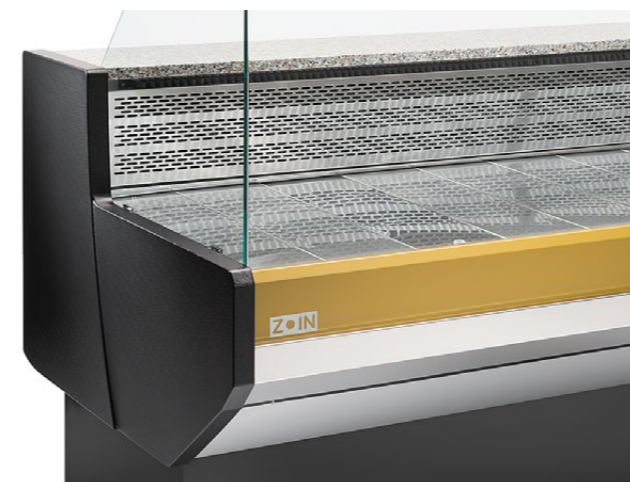



# PATAGONIA

Versions

Gray Black Optional

Colori spalla  
End colours  
Couleurs des côtés  
Farben für Rückwände

C-1

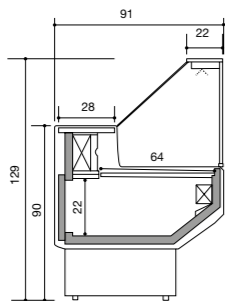

Statico con cella  
Static with cool storage  
Statique avec réserve  
Statisch mit Unterbaukuehlung

C-2

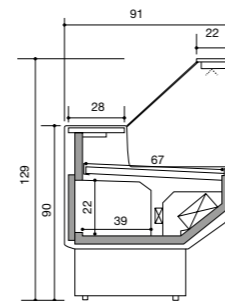

Ventilato con cella  
Ventilated with cool storage  
Ventiléé avec réserve  
Umluft mit Unterbaukuehlung

Y-1

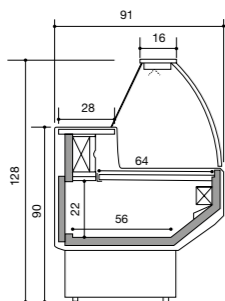

Statico con cella  
Static with cool storage  
Statique avec réserve  
Statisch mit Unterbaukuehlung

Y-2

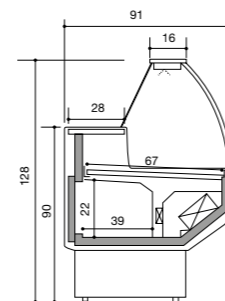

Ventilato con cella  
Ventilated with cool storage  
Ventiléé avec réserve  
Umluft mit Unterbaukuehlung



Eye-catching by design.

Z•IN



# TIBET



Width in cm.

79



Length in cm.

100 · 150  
200 · 250  
300



Climate class

3 M2  
25°C / u.r. 60%

## Fai grande il tuo punto vendita in poco spazio.

Tibet è l'espositore perfetto per gli ambienti più ristretti, grazie ai suoi soli 79 cm di larghezza totale.

È studiato per massimizzare l'esposizione di salumi, formaggi e piatti pronti, l'ideale per ogni esigenza che richieda un banco refrigerato.

### Make your store big in small space.

With a total width of only 79 cm, Tibet is perfect for small stores. Designed to enhance cold cuts, cheese and ready meals, can cater to any refrigerated counter needs.

### Votre espace de vente s'agrandit sur peu d'espace.

Tibet est le présentoir parfait pour les espaces les plus restreints, grâce à sa largeur totale de 79 cm. Il est conçu pour maximiser l'exposition de charcuteries, de fromages et de plats préparés, l'idéal pour chaque exigence qui requiert un comptoir réfrigéré.

### Machen Sie Ihr Geschäft auf kleinem Raum groß.

Tibet ist dank seiner Gesamtbreite von nur 79 cm die perfekte Auslage für kleinste Räume. Es wurde für die Auslage von Aufschnitt, Käse und Fertiggerichten entwickelt und ist ideal für jeden Einsatz, der eine Kühltheke erfordert.



D97 Black Version C-1



# TIBET

Green  
Version  
B-1

D101

White Oak  
Version  
B-1

D136



1

Struttura e cappello in vetro.  
Top and upper glass structure.  
Structure et chapeau en verre.  
Glas und Zahlplatte Struktur.

2

Illuminazione LED.  
LED lighting.  
Éclairage LED  
LED-Beleuchtung

3

Zona esposizione in acciaio Inox.  
Display area in stainless steel.  
Zone d'exposition en acier inox.  
Auslagefläche aus Edelstahl.

4

Nr. 1 vetro intermedio.  
Nr. 1 intermediate shelf.  
Nr. 1 vitre intermédiaire.  
Nr. 1 Zwischenglaselage.

5

Piano lavoro in granito (Rosa Beta).  
Working plate in granit (Rosa Beta).  
Plan de travail en granit (Rosa Beta).  
Arbeitsplatte aus (Rosa Beta).





## TIBET Versions

Gray Black Optional

Colori spalla  
End colours  
Couleurs des côtés  
Farben für Rückwände

B-1

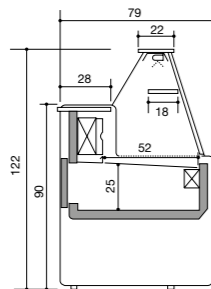

Statico con cella - Vetro dritto

Static with cool storage -  
Straight glass

Statique avec réserve - Vitre droite

Statisch mit Unterbaukuehlung -  
Gerades Glas

C-1

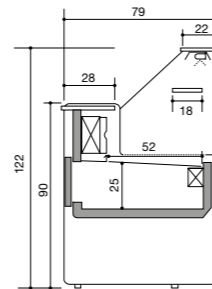

Statico con cella - Vetro retto

Static with cool storage -  
Upright glass

Statique avec réserve - Vitre verticale

Statisch mit Unterbaukuehlung -  
Rechteckiges Glas

Unlimited performance  
in a limited space.



Z•IN



# SAIGON



## La soluzione più efficiente per la vendita del pesce.

Importante quanto delicata, l'esposizione del pesce necessita di un prodotto professionale ad hoc: Saigon è lo strumento perfetto per questa tipologia di alimento. I pratici gamboni in acciaio Inox, forniti di serie, garantiscono facile e veloce pulizia dell'ambiente.

### The most efficient solution for the sale of fish.

The delicate displaying and preservation of fish require a professional and specifically designed product: Saigon is the perfect counter for fish. The convenient stainless steel support legs, now provided as standard, enable fast and easy cleaning.

### La solution la plus efficace pour la vente de poissons.

L'exposition du poisson est importante et délicate et nécessite d'un produit professionnel ad hoc: Saigon est l'outil parfait pour cette typologie d'aliment. Les gros pieds pratiques en acier inox, fournis de série, garantissent un nettoyage rapide et facile de l'espace de vente.

### Die effizienteste Lösung für den Verkauf von Fisch.

Die wichtige und delikate Präsentation von Fisch benötigt ein professionelles Ad-hoc-Produkt: Saigon ist der perfekte Aussteller für diese Art von Lebensmitteln. Die praktischen Edelstahlbeine, die serienmäßig mitgeliefert werden, ermöglichen eine einfache und schnelle Reinigung der Räumlichkeiten.

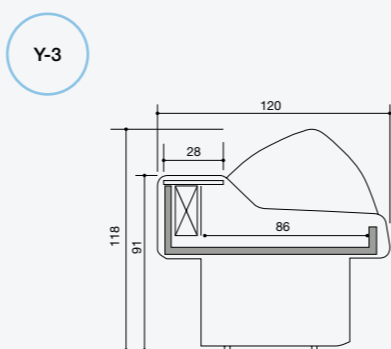
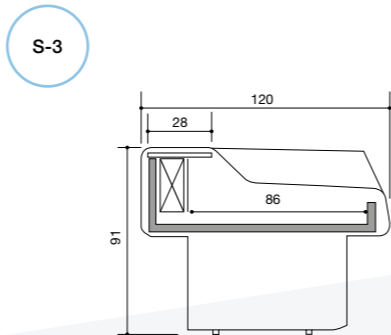

- 1 Ideale per esposizione e vendita del pesce.  
Ideal for display and sale of fish.  
Ideal pour l'exposition et la vente de poisson.  
Ideal für die Ausstellung und Verkauf von Fisch.
- 2 Zona esposizione in acciaio AISI 316.  
Display area in stainless steel AISI 316.  
Zone d'exposition en acier AISI 316.  
Auslagefläche aus Edelstahl AISI 316.
- 3 Piano lavoro in granito (Rosa Beta).  
Working plate in granit (Rosa Beta).  
Plan de travail en granit (Rosa Beta).  
Arbeitsplatte aus (Rosa Beta).
- 4 Vetro curvo.  
Curved glass.  
Vitre bombée.  
Gebogene Scheibe.

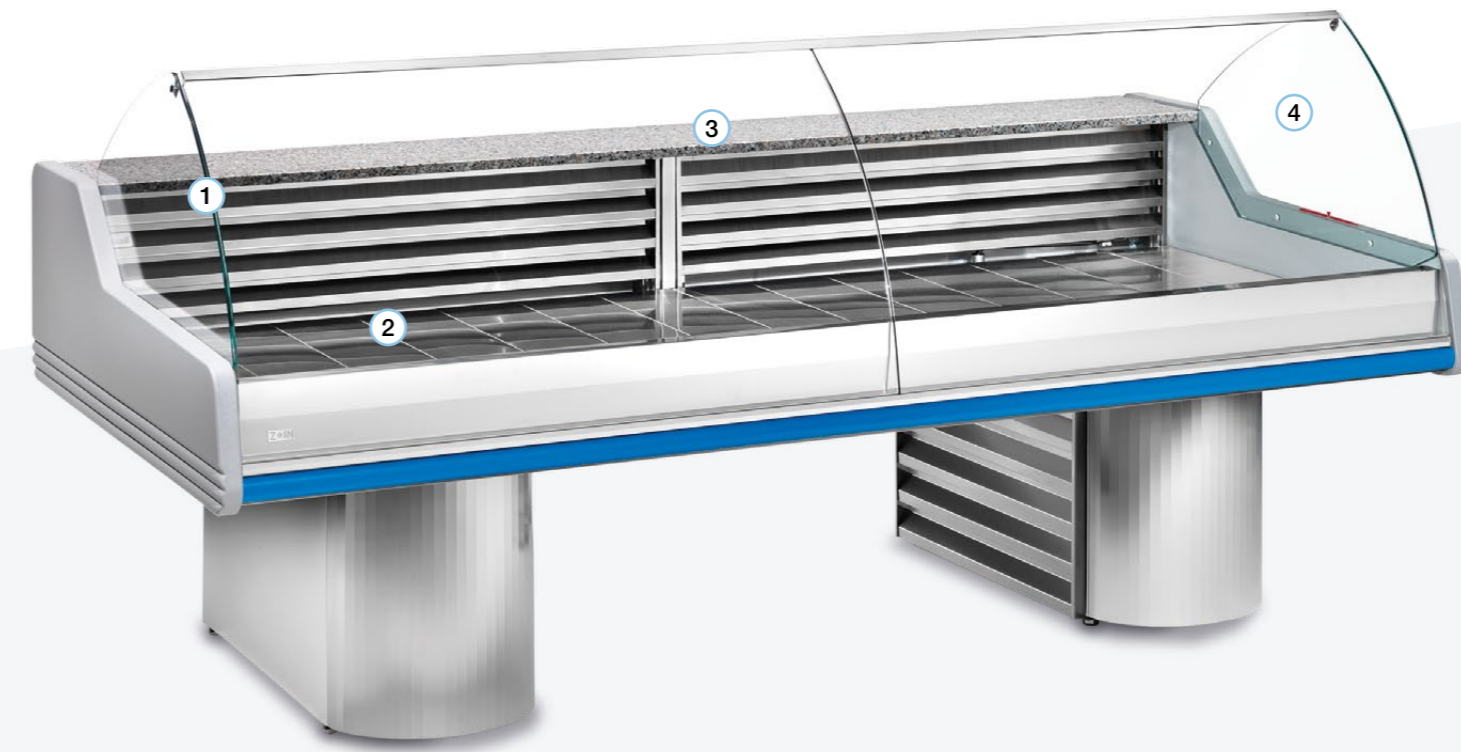

Gray

Colori spalla  
End colours  
Couleurs des côtés  
Farben für Rückwände

- Width in cm.  
120
- Length in cm.  
150 · 200 · 250  
300 · 350
- Climate class  
3 M1  
25°C / u.r. 60%

Version Y-3



# MELODY



## Un modello senza tempo.

Melody è sinonimo di tradizione e robustezza, un modello che non segue le mode del momento. L'abbiamo progettato per la presentazione e la vendita di salumi, formaggi e altri prodotti di gastronomia.

**A timeless model.**  
Melody rhymes with tradition and robustness without conforming with new trends. It has been designed for the display of cold cuts, cheese and gastronomic products in general.

**Un modèle intemporel.**  
Melody est synonyme de tradition et de robustesse, un modèle qui ne suit pas les modes actuelles. Nous l'avons conçu pour la présentation et la vente de charcuteries, de fromages et d'autres produits préparés.

**Ein zeitloses Modell.**  
Melody ist ein Synonym für Tradition und Stabilität, ein Modell, das sich nicht an den Moden des Augenblicks orientiert. Wir haben es für die Präsentation und den Verkauf von Wurstwaren, Käse und anderen gastronomischen Produkten konzipiert.

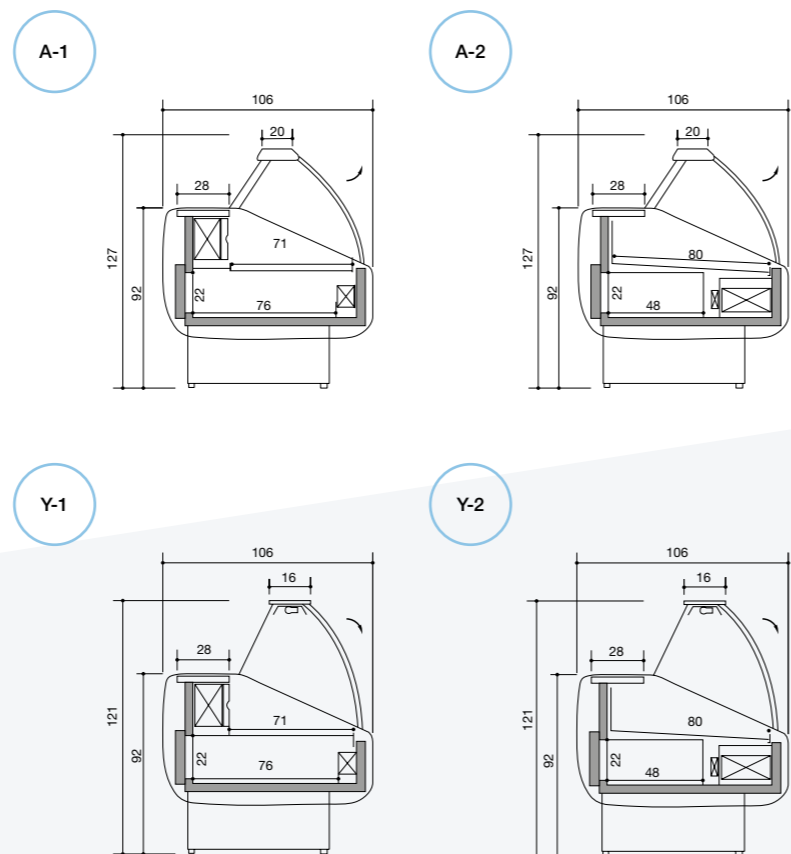

**1**  
Illuminazione LED.  
LED lighting.  
Éclairage LED.  
LED-Beleuchtung.

**2**  
Zona esposizione in acciaio Inox.  
Display area in stainless steel.  
Zone d'exposition en acier inox.  
Auslagefläche aus Edelstahl.

**3**  
Piano lavoro in granito (Rosa Beta).  
Working plate in granit (Rosa Beta).  
Plan de travail en granit (Rosa Beta).  
Arbeitsplatte aus (Rosa Beta).

**4**  
A1- A2: Struttura servoassistita.  
A1- A2: Servo-assisting upsetting glass.  
A1- A2: Overture servoassistite.  
A1- A2: Hebescheibenstruktur.

**5**  
Y1-Y2: vetri apribili a compasso.  
Y1-Y2: bottom-hung glass.  
Y1-Y2: vitre rabattable.  
Y1-Y2: Gerade Kippscheiben.



**D96** Red Version Y-2

Gray

Colori spalla  
End colours  
Couleurs des côtés  
Farben für Rückwände

**Width in cm.**  
106

**Length in cm.**  
150 · 200 · 250  
300 · 350 · 400

**Climate class**  
3 M2  
25°C / u.r. 60%



# COLORADO



Width in cm.

98



Length in cm.

140 · 220  
290



Climate class

3 H2  
25°C / u.r. 60%

## Eleganza per la pasticceria.

La vetrina perfetta per esporre la pasticceria refrigerata o secca con un'eleganza e una capacità espositiva che non hanno eguali. Progettato per massimizzare l'esposizione verticale, Colorado è un banco elegante che si armonizza con ogni ambiente di vendita.

### Elegance at the pastry shop.

This display is perfect to showcase both fresh and dry pastry creations with unparalleled elegance and display quality. Designed to enhance vertical display, Colorado is an elegant counter that attunes with any styles and store.

### Élégance pour la pâtisserie.

La vitrine parfaite pour exposer les pâtisseries réfrigérées ou sèches avec une élégance et une capacité d'exposition sans pareil. Conçue pour maximiser l'exposition verticale, Colorado est un présentoir élégant qui s'harmonise très bien avec n'importe quel espace de vente.

### Eleganz für die Feinbäckerei.

Die perfekte Vitrine für die Präsentation von gekühltem oder trockenem Gebäck mit einer Eleganz und Auslagekapazität, die ihresgleichen sucht. Colorado ist eine elegante Theke, die für eine maximale vertikale Präsentation ausgelegt ist und sich harmonisch in jede Verkaufsumgebung einfügt.



D136 White Oak  
Version  
C-3



# COLORADO

White Butter  
Version  
Y-3 D151

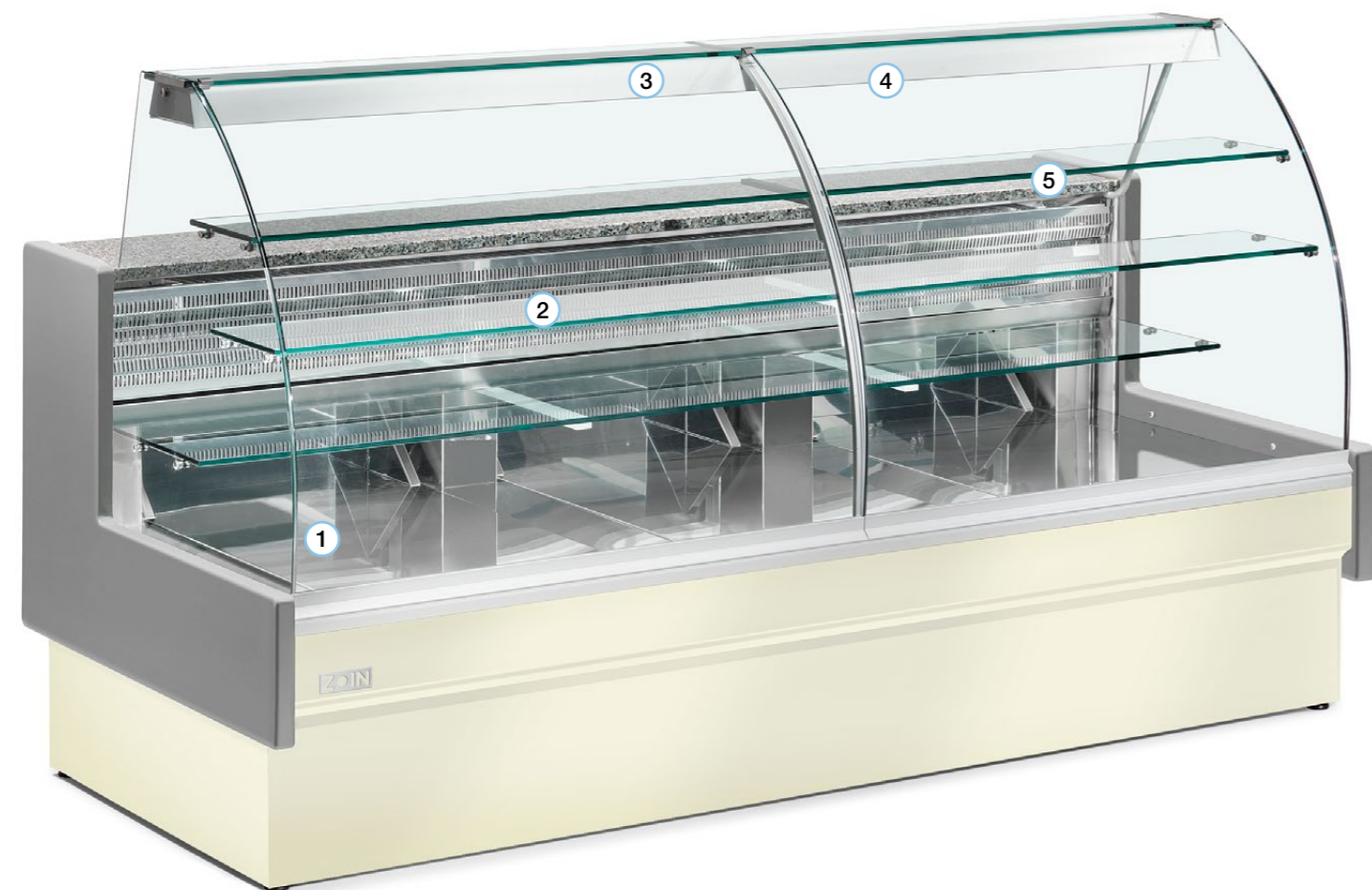

1

Zona esposizione in acciaio Inox.  
Display area in stainless steel.  
Zone d'exposition en acier inox.  
Auslagefläche aus Edelstahl.

2

Ripiani in vetro non refrigerati.  
Non-refrigerated glass shelves.  
Étagères en verre non réfrigérées.  
Nicht-gekühlte Glasregale.

3

Vetri apribili a compasso (C-3 e Y-3).  
Bottom-hung glass (C-3 e Y-3).  
Vitre rabattable (C-3 e Y-3).  
Gerade Kippscheiben (C-3 e Y-3).

4

Illuminazione LED.  
LED lighting.  
Éclairage LED.  
LED-Beleuchtung.

5

Piano lavoro in granito (Rosa Beta).  
Working plate in granit (Rosa Beta).  
Plan de travail en granit (Rosa Beta).  
Arbeitsplatte aus (Rosa Beta).

## COLORADO Versions

Gray Black Optional

Colori spalla.  
La parte inferiore della spalla è personalizzabile con il colore del frontale scelto.

End colours.  
The lower part of the sidewall can be customised with the colour of the chosen front.

Couleurs des côtés.  
La partie inférieure du côté est personnalisable avec la couleur de la face avant choisie.

Farben für Rückwände.  
Der untere Teil der Rückwand kann farblich an die gewählte Front angepasst werden.

C-3

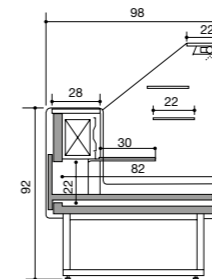

Statico con cassettoni scorrevole  
Static with sliding drawer  
Statique avec tiroir coulissant  
Statisch mit Schublade

Y-3

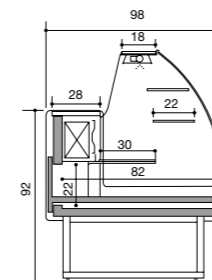

Statico con cassettoni scorrevole  
Static with sliding drawer  
Statique avec tiroir coulissant  
Statisch mit Schublade





1

Cappello in vetro.  
Upper glass.  
Chapeau en verre.  
Zahlplatte aus Glas.

2

illuminazione LED.  
LED lighting.  
Éclairage LED.  
LED-Beleuchtung.

3

Zona esposizione in acciaio Inox.  
Display area in stainless steel.  
Zone d'exposition en acier inox.  
Auslagefläche aus Edelstahl.

## Pronto a soddisfare tutte le esigenze.

VR è l'espositore refrigerato versatile ed economico adatto a qualsiasi esigenza. Ideale nel mondo della ristorazione per esibire piatti pronti, sandwich, prodotti gastronomici o pesce fresco.

**Ready to cater to your needs.**  
VR is a versatile and low-cost refrigerated counter that can suit any needs. Perfect for catering display of ready dishes, sandwiches, gastronomic products or fresh fish.

**Prêt pour satisfaire toutes les exigences.**  
VR est le présentoir réfrigéré universel et économique adapté à toutes les exigences. Il est idéal dans le monde de la restauration pour présenter les plats préparés, les sandwichs, les produits gastronomiques ou les poissons frais.

**Bereit, allen Anforderungen gerecht zu werden.**  
VR ist der vielseitige und preisgünstige Kühlaussteller, der für jeden Bedarf geeignet ist. Ideal in der Welt der Gastronomie, um Fertiggerichte, Sandwiches, kulinarische Produkte oder frischen Fisch auszustellen.

B-7

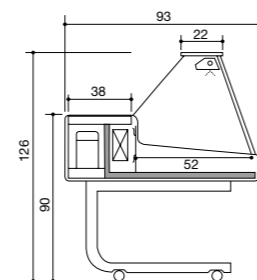

S-7

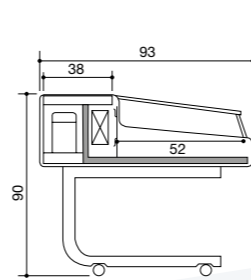

Y-7

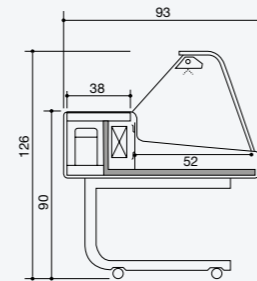

Y-7 Fish

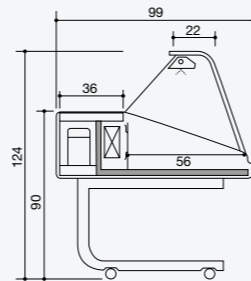

Gray

Colori spalla  
End colours  
Couleurs des côtés  
Farben für Rückwände



Width in cm.  
93/99



Length in cm.  
100 - 150



Climate class  
Y7: 3 M2  
Y7 Fish: 3 M1  
25°C / u.r. 60%

Version  
Y-7



# SERVE-OVER

<b>A</b>		<b>VETRO CURVO</b> APRIBILE VERSO L'ALTO
<b>B</b>		<b>VETRO DRITTO</b> APRIBILE A COMPASSO
<b>C</b>		<b>VETRO RETTO</b> APRIBILE A COMPASSO
<b>D</b>		<b>VETRO RETTO</b> APRIBILE VERSO L'ALTO
<b>Y</b>		<b>VETRO CURVO</b> APRIBILE A COMPASSO
<b>S</b>		<b>VETRO SELF SERVICE</b>

<b>1</b>	STATICO CON CELLA
<b>2</b>	VENTILATO CON CELLA
<b>3</b>	STATICO SENZA CELLA
<b>4</b>	VENTILATO SENZA CELLA
<b>5</b>	CALDO
<b>6</b>	NON REFRIGERATO
<b>7</b>	CON SUPPORTO E RUOTE
<b>8</b>	SENZA SUPPORTO E RUOTE
<b>FISH</b>	VERSIONE PER PESCE

<b>A</b>		<b>CURVED GLASS</b> OPENING UPWARDS
<b>B</b>		<b>STRIGHT GLASS</b> OPENING DOWNWARDS
<b>C</b>		<b>VERTICAL GLASS</b> OPENING DOWNWARDS
<b>D</b>		<b>STRIGHT GLASS</b> OPENING UPWARDS
<b>Y</b>		<b>CURVED GLASS</b> OPENING DOWNWARDS
<b>S</b>		<b>GLASS SELF SERVICE</b>

<b>1</b>	STATIC WITH COOL STORAGE
<b>2</b>	STATIC WITH COOL STORAGE
<b>3</b>	STATIC WITHOUT COOL STORAGE
<b>4</b>	VENTILATED WITHOUT COOL STORAGE
<b>5</b>	HOT-SECTION
<b>6</b>	NOT REFRIGERATED
<b>7</b>	WITH SUPPORT AND CASTORS
<b>8</b>	WITHOUT SUPPORT AND CASTORS
<b>FISH</b>	FISH VERSION

<b>A</b>	SPALLE A "BLOCCHI"
<b>B</b>	RIPIANI INCLINABILI CREMAGLIERE
<b>F</b>	FRUTTA VERDURA CREMAGLIERE+ SPECCHIO
<b>SG</b>	SENZA GRUPPO INCORPORATO
<b>FG</b>	SENZA GRUPPO INCORPORATO FRUTTA VERDURA
<b>VIEW</b>	MURALI CON PORTE A VETRI SCORREVOLI

<b>130</b>	H MURALE CIRCA 130 CM.
<b>130N</b>	H MURALE CIRCA 130 CM. BATTICARRELLO PLASTICA
<b>130L</b>	H MURALE CIRCA 130 CM. BATTICARRELLO INOX VETRINO FRONTALE
<b>160</b>	H MURALE CIRCA 160 CM.
<b>180</b>	H MURALE CIRCA 180 CM.
<b>190</b>	H MURALE CIRCA 190 CM.
<b>200</b>	H MURALE CIRCA 200 CM.
<b>B20 B30</b>	RETROBANCO CON BASAMENTO
<b>P20 P30</b>	RETROBANCO PENSILE DA APPENDERE O APPOGGIARE

# SELF SERVICE DISPLAY

<b>A</b>	ENDWALLS WITH BLOCKS
<b>B</b>	INCLINABLE SHELVES WITH RACK
<b>F</b>	FRIUT & VEGETABLES WITH RACK AND MIRROR
<b>SG</b>	WITHOUT BUILT UNIT
<b>FG</b>	WITHOUT BUILT UNIT FRIUT & VEGETABLES
<b>VIEW</b>	REFRIGERATED WALL CABINET WITH SLIDING DOORS

<b>130</b>	REF. WALL CABINET APROX H 130 CM.
<b>130N</b>	REF. WALL CABINET APROX H 130 CM. PLASTIC BUMPER
<b>130L</b>	REF. WALL CABINET APROX H 130 CM. INOX BUMPER & FRONT GLASS
<b>160</b>	REF. WALL CABINET APROX H 180 CM. PLASTIC BUMPER
<b>180</b>	REF. WALL CABINET APROX H 180 CM. PLASTIC BUMPER
<b>190</b>	REF. WALL CABINET APROX H 190 CM.
<b>200</b>	REF. WALL CABINET APROX H 200 CM.
<b>B20 B30</b>	BACK-COUNTER WITH LOWER STRUCTURE
<b>P20 P30</b>	BACK-COUNTER FOR HANGING OR PLACING ON LOWER STRUCTURE

# COLORI

Colori disponibili  
Available colors  
Couleurs disponibles  
Verfügbare Farben

Batticarrello  
Bumpers  
Pare-chocs  
Stoßfänger

