

IT | Un nuovo concept di vetrine espositive **PROFESSIONALI** per gelaterie, pasticcerie, panetterie e tavole calde. Moderna e raffinata, **COMETA** può essere installata in qualsiasi locale, grazie alla sua struttura **COMPATTA** (solo 98 centimetri).

- Scocca monoblocco con isolamento in poliuretano, vasca in acciaio inox AISI 304.
- Illuminazione a LED.
- Alzata vetri riscaldati anticondensa, apertura del vetro frontale a compasso, chiusura lato servizio con tendina auto avvolgente o scorrevoli in plexiglass.
- Refrigerazione ventilata.
- Doppio compressore ermetico V230/1 (nei modelli 18 e 24) per ottime prestazioni frigo, con basso livello di rumorosità.
- Optional compressore 400/3.
- Unità condensatrice estraibile per una manutenzione semplice e veloce.
- Sbrinamento automatico ultrarapido, ad inversione di ciclo.
- Quadro comandi elettronico per la regolazione della temperatura.
- Classe climatica 7 (35°/ 75% UR).

EN | A new concept of **PROFESSIONAL** showcases for ice cream parlors, pastry shops, bakeries and snack bars. Modern and sophisticated, **COMETA** can be installed in any bar thanks to its **COMPACT** structure (only 98 centimeters deep).

- One-piece shell polyurethane insulation, AISI 304 stainless steel tank.
- LED lighting.
- Anti-condensation heated glass superstructure, vent-opening front glass, service side closure with wraparound curtain or sliding Plexiglass doors.
- Ventilated refrigeration.
- Double hermetic compressor V230/1 (in models 18 and 24) for optimal refrigeration performance with low noise level.
- Optional compressor 400/3.
- Removable condensing unit for easier, faster maintenance.
- Automatic ultra-fast reverse cycle defrost.
- Electronic control panel for temperature adjustment.
- Climate class 7 (35°/ 75% UR).

EUROPROJET
PROVOCATEUR DE FROID

COMETA



GELATO
Gelato
Gelato
Gelato



PASTICCERIA
Pastry
Konditorei
Pâtisserie



PRALINERIA
Praline
Pralinen
Pralinerie



CALDO A SECCO
Dry heat
Trockene Wärme
Chaud à sec



BAGNO MARIA
Bain marie
Wasserbad
Bain marie

DE | Ein neues Konzept von PROFESSIONAL-Vitrinen für Eisdiele, Konditoreien, Bäckereien und Snackbars.
Modern und raffiniert, COMETA kann dank seiner COMPACT-Struktur in jedem Lokal installiert werden (nur 98 Zentimeter tief).

- Monoblock-Gehäuse mit Polyurethan-Hartschaumisolierung, Edelstahlwanne AISI 304.
- LED-Beleuchtung.
- Beheizter Glasaufsatz mit Wärmedämmverglasung, Frontscheibe mit Klappöffnung, Schließung der Bedienerseite mit Thermorollo oder Plexiglas-Schiebescheibe.
- Umluftkühlung.
- Doppelter hermetischer Kompressor V230/1 (für Modelle 18 und 24) für erstklassige Kühlleistung, extrem geräuscharm.
- Optional erhältlicher Kompressor 400/3.
- Entnehmbares Verflüssigeraggregat für einfache und rasche Wartung.
- Ultraschnelle automatische Abtauung durch Zyklusinversion.
- Elektronisches Schaltpult zum Einstellen der Temperatur
- Klimaklasse 7 (35°/ 75% UR).

FR | Un nouveau concept de vitrines d'exposition PROFESSIONNELLES pour glaciers, pâtisseries, boulangeries et snack-bars.
Moderne et raffinée, COMETA peut être installée dans tout type de local grâce à sa structure COMPACTE (seulement 98 centimètres).

- Châssis monobloc avec isolation en polyuréthane, cuve en acier inox AISI 304.
- Éclairage à LED.
- Montant vitres réchauffées anti-condensation, ouverture de la vitre frontale par compas, fermeture côté service avec rideau à enroulement automatique ou coulissant en plexiglas.
- Réfrigération ventilée.
- Double compresseur hermétique V230/1 (dans les modèles 18 et 24) pour des performances de réfrigération optimales, avec niveau de bruit bas.
- Compresseur 400/3 optionnel.
- Unité de condensation amovible pour un entretien simple et rapide.
- Dégivrage automatique ultra rapide, à cycle inversé.
- Tableau de commandes électronique pour le réglage de la température.
- Classe climatique 7 (35°/ 75% UR).

COMETA



GELATO
Gelato
Gelato
Gelato

Single air flow

-16 / -18 (°C)

7 (35°C / 75%UR)

POTENZA COMPRESSORE

POWER COMPRESSOR
PUISSANCE COMPRESSEUR
LEISTUNG VERDICHTER

TENSIONE
Supply
Spannung
Tension

POTENZA ASSORBITA
Electrical power output
Absorbierte Leistung
Puissance absorbée

SBRINAMENTO
In Defrost
Zeitgesteuerte
Dégivrage

Monofase Single-phase Einphasig Monophasé	12 18 24	230 V 1 Ph 50 Hz	1,51 kW 2,08 kW 2,5 kW	2,15 kW 3,53 kW 3,8 kW
Trifase Three-phase Dreiphasig Triphasé	12 18 24	400 V 3 Ph 50 Hz	1,3 kW 1,97 kW 2,8 kW	2,52 kW 3,87 kW 5,1 kW

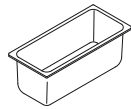

STANDARD

5 Lt. (360 x 165 x 120h)

7 Lt. (360 x 165 x 150h)

LARGE

5,4 Lt. (360 x 250 x 80h)

8 Lt. (360 x 250 x 120h)

11 Lt. (360 x 250 x 150h)

H1220

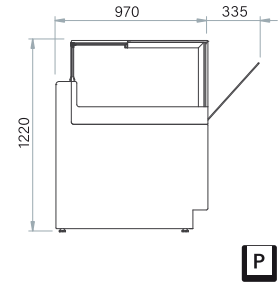
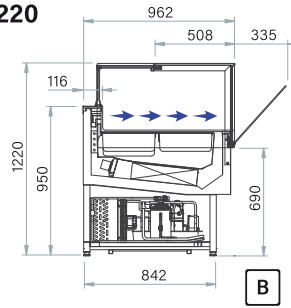

H1380

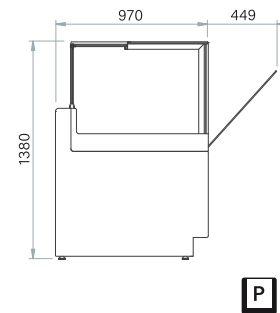
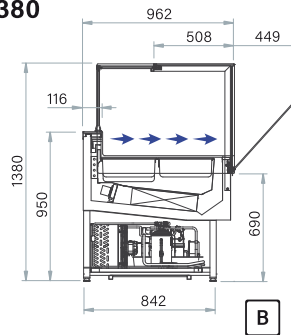

12

235 kg (H1220)

245 kg (H1380)

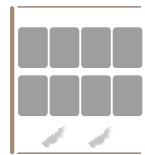
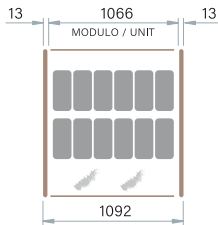

H1220
H1380

B CMT12-VD-H122-B

P CMT12-VD-H122-P

B CMT12-VD-H138-B

P CMT12-VD-H138-P

18

325 kg (H1220)

335 kg (H1380)

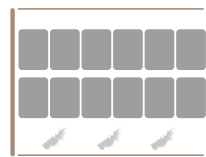
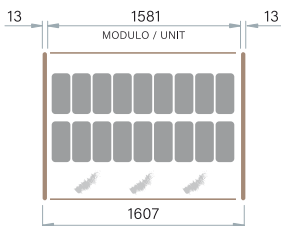

H1220
H1380

B CMT18-VD-H122-B

P CMT18-VD-H122-P

B CMT18-VD-H138-B

P CMT18-VD-H138-P

24

390 kg (H1220)

400 kg (H1380)

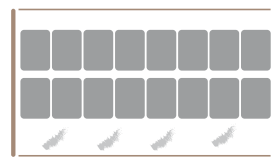
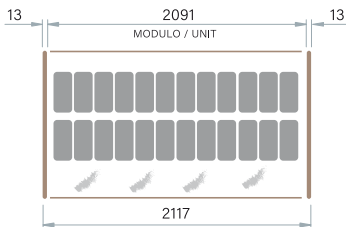

H1220
H1380

B CMT24-VD-H122-B

P CMT24-VD-H122-P

B CMT24-VD-H138-B

P CMT24-VD-H138-P

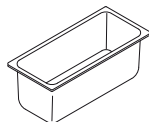

12	18	24
1220 x 1270 x 1560h	1720 x 1270 x 1560h	2260 x 1270 x 1560h
270 / 280 kg	357 / 367 kg	470 / 480 kg

**OPTIONAL***Optional**Wahlweise**Optionnel***VASCHETTE GELATO***S/s containers**Eisschalen**Bac***MODELLO / Model**
*Modell / Modèl***CODICE / Code**
Code / Code

360 x 165 x 120

VSC04/P120

360 x 165 x 150

VSC04/P150

360 x 250 x 080

VSC04/P080

360 x 250 x 120

VSC10/P120

360 x 250 x 150

VSC10/P150

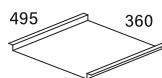
**PIANI INOX***S/s trays**Edelstahlebenen**Plans inox*

COMETA 12

VSX110/12

COMETA 18

VSX160/18

COMETA 24

VSX210/24

**KIT STECCHI***Icecle kit**Stieleis-kit**Kit pour stecchi*

/

STECCHI

[*] Per singola vaschetta / For each container / Für jeden eisschalen / Pour chaque conteneur

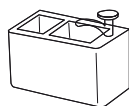
**LAVAPORZIONATORE***Scoop washer**Waschvorrichtung speiseeisausformer**Lave-cuillère à glace*Standard/Standard
Standard/Standard

LVCS

Con doccia /With shower
Mit ausziehbrause /
Avec douch

LVCDP

**PORTACONI***Cone holder**Kegelhalter**Porte-cônes*

/

PTCN

**ILLUMINAZIONE LED FRONTALE***Frontal led lights system**Frontales led-lichtsystem**Système d'éclairage à del frontale*

L=1100

IG-110

L=1600

IG-160

L=2100

IG-210

**KIT RUOTE***Castors kit**Rollen kit**Kit roulettes*

/

RUOTE

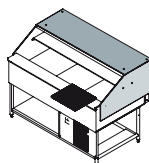
**PIANO PORTA BILANCIA INOX***S/s scale-holder countertop addition**Waageträgerebene edelstahl**Plan porte-balance inox*

/

PIPB

**DIVISORIO BASSO IN VETRO***Low glass divider**Tiefer trennelement aus glas**Séparateurs bas en verre*

RISCALDATO

VDR

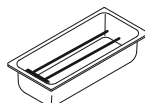
**VASCHETTA INOX EVAPORA CONDENSA ELETTRICA***(Electrical) stainless steel condensation container for evaporation**(Elektrisches) kondensbehälter aus rostfreies stahl**(Électrique) bac en acier inoxydable pour l'évaporation de la condensé*

/

VSRC-INOX

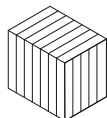
**CASSA IN LEGNO PER TRASPORTO***Wooden boxes for transporting**Holzklste für den transport**Caisse en bois pour transport*

/

BOX

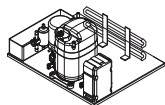
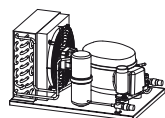
**OPTIONAL***Optional
Wahlweise
Optionnel***MAGGIORAZ. CONDENSAZIONI U.C.***Condensing unit
Aufschlag kondensation verflüssigereinheit v.E.
Majoration condensation u.C***PREDISPOSIZIONE U.C. EST.***Remote cond. Unit preparation
Vorbereitung externe v.E.
Prédisposition u.C externe***380V****ERMETICO O SEMIERMETICO***Hermetic or semi-hermetic
Hermetisch oder halbhermetisch
Hermétique ou semi-hermétique***60Hz****60HZ**
*60hz
60hz
60hz***SUPPLEMENTO TEMP. +***Extra cost for positive temperature
Zuschlag positive temperatur
Supplément température positive***SEPARATORE OLIO***Oil separator
Ölabscheider
Séparateur d'huile***SISTEMA DI CONTROLLO REMOTO***Remote control system
Fernbedienungssystem
Système de commande à distance***MODELLO / Model**
*Modell / Modèl***CODICE / Code**
Code / Code

Ad acqua/Water

Mit wasser /À eau

C-AQ

Aria-acqua/Aria-acqua

Luft-Wasser/Air-Eau

C-AR/AQ

Hydronic system

*Hydronic system
Hydronisches System
Système hydronique*

HYDG

Tropicalizzato per u.c. remota

*Tropicalised
Tropensicher
Tropicalisé*

CTR

Insonorizzato per u.c. remota

*Soundproofed
Schallgedämpft
Insonorisé*

CIR

[] Da definire in fase di progetto / To be defined in the project phase / In der planungsphase festzulegen / À définir au moment du projet*

230 V [**]

PUEE

380 V [*] [**]

PUES

*Per la predisposizione all'impianto centralizzato chiedere il preventivo all'ufficio commerciale
To set up the centralized system, ask the sales office for a quote
Um die zentrale Anlage einzurichten, fragen Sie den Verkaufsbüro
Pour mettre en place le système centralisé, demandez un devis au bureau des ventes**[*] Per la versione 380 V è possibile richiedere il motore Semiermetico
For the 380V version can be requested engine Semi-hermetic
Für die version 380 v kann der halbhermetische motor angefragt werden
Pour la version 380 v il est possible de demander le moteur semi-hermétique**[**] NO per Hydronic System
NOT available for hydronic systems
NICHT für hydronische Systeme verfügbar
NON disponible pour le système hydronique*

COMETA 12

380V-12

COMETA 18

380V-18

COMETA 24

380V-24

/

UC60HZ

/

STPS

/

SOL

/

RCS



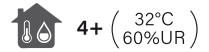
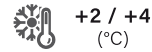

H1220

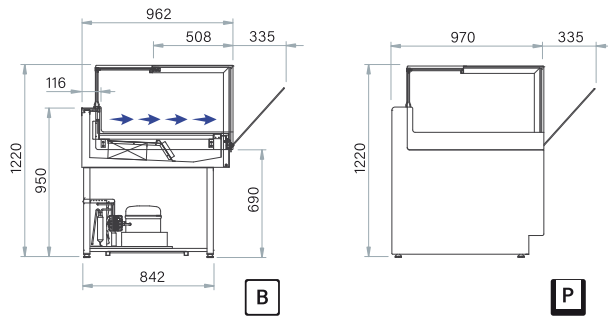

H1380

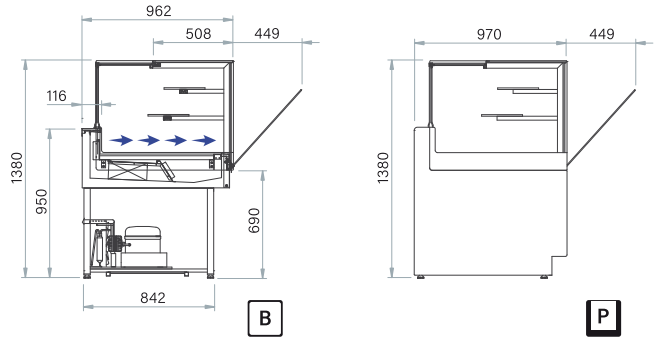

POTENZA COMPRESSORE / POWER COMPRESSOR / PUISSANCE COMPRESSEUR / LEISTUNG VERDICHTER

PAST 110	PAST 160	PAST 210	PAST 90° DX	PAST 90° SX
----------	----------	----------	-------------	-------------

TENSIONE / Supply / Spannung / Tension

230 V / 1 Ph / 50 Hz

POTENZA ASSORBITA / Electrical power output Absorbierte Leistung / Puissance absorbée

0,66 kW	0,85 kW	1,1 kW	0,85 kW	0,85 kW
---------	---------	--------	---------	---------

PAST 110

214 kg (H1220)
224 kg (H1380)

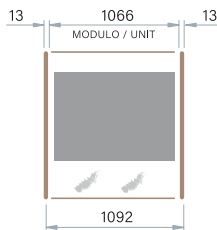

PAST 160

285 kg (H1220)
302 kg (H1380)

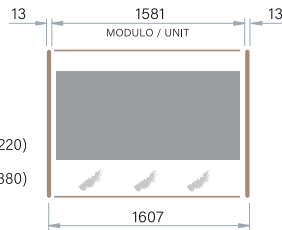

PAST 210

337 kg (H1220)
353 kg (H1380)

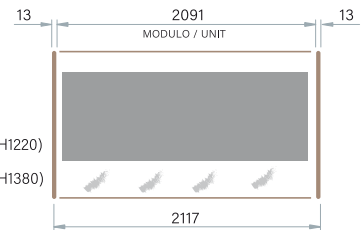

H1220 [B] CMT110-VD-H122-B
[P] CMT110-VD-H122-P

H1220 [B] CMT160-VD-H122-B
[P] CMT160-VD-H122-P

H1220 [B] CMT210-VD-H122-B
[P] CMT210-VD-H122-P

H1380 [B] CMT110-VD-H138-B
[P] CMT110-VD-H138-P

H1380 [B] CMT160-VD-H138-B
[P] CMT160-VD-H138-P

H1380 [B] CMT210-VD-H138-B
[P] CMT210-VD-H138-P

PAST 90° DX

325 kg (H1220)
335 kg (H1380)

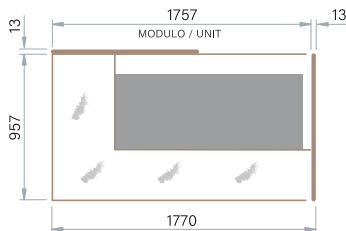

PAST 90° SX

325 kg (H1220)
335 kg (H1380)

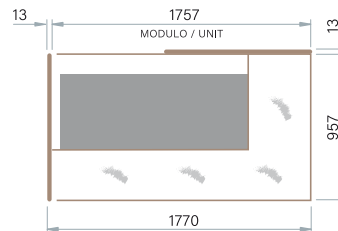

H1220 [B] CMTDX-VD-H122-B
[P] CMTDX-VD-H122-P

H1220 [B] CMTSX-VD-H122-B
[P] CMTSX-VD-H122-P

H1380 [B] CMTDX-VD-H138-B
[P] CMTDX-VD-H138-P

H1380 [B] CMTSX-VD-H138-B
[P] CMTSX-VD-H138-P

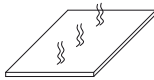
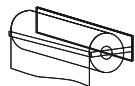
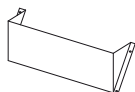
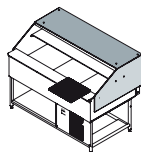
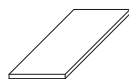
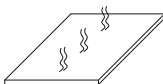
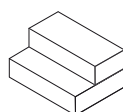
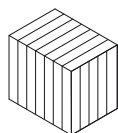

PAST 110	PAST 160	PAST 210	PAST 90° DX	PAST 90° SX
1220 x 1270 x 1560h	1720 x 1270 x 1560h	2260 x 1270 x 1560h	1790 x 1200 x 1550h	1790 x 1200 x 1550h
254 / 260 kg	330 / 342 kg	396 / 400 kg	330 / 342 kg	330 / 342 kg

**OPTIONAL***Optional**Wahlweise**Optionnel***PIANO CALDO ESPOSIZIONE***Warm display top
Warmebeine für ausstellung
Plan chaud d'exposition***RULLO PORTACARTA***Paper roll holder
Papierträgerrolle
Rouleau porte-papier***TASCA PORTACARTA***Bag holder bag holder
Papierträgertasche
Poche porte-papier***KIT RUOTE***Castors kit
Rollen kit
Kit roulettes***PIANO PORTA BILANCIA INOX***S/s scale-holder countertop addition
Waagträgerebene edelstahl
Plan porte-balance inox***DIVISORIO BASSO IN VETRO***Low glass divider
Tiefer trennelement aus glas
Séparateurs bas en verre***MENSOLA SUPPLEMENTARE***Extra shelf
Extra regal
Plateau extra***MENSOLA CALDA***Warm shelf
Warm regal
Plateau chaud***GRADINO INOX***S/s step
Edelstahlstufen
Étape inox***CASSA IN LEGNO PER TRASPORTO***Wooden boxes for transporting
Holzkiste für den transport
Caisse en bois pour transport***MODELLO / Model**
*Modell / Modèl***CODICE / Code**
Code / Code

L=1100

PCE-110

L=1600

PCE-160

L=2100

PCE-210

90°

PCE-90°CMT

/

RPC

/

TPCT

/

RUOTE

/

PIPB

NEUTRO

VDN

RISCALDATO

VDR

L=1100

MII-110

L=1600

MII-160

L=2100

MII-210

90°

MII-90°CMT

[*] Illuminazione NON inclusa / Lighting NOT included / Beleuchtung nicht inbe

L=1100

MCD-110

L=1600

MCD-160

L=2100

MCD-210

90°

MCD-90°CMT

[*] Illuminazione NON inclusa / Lighting NOT included / Beleuchtung nicht inbegriffen / Éclairage NON inclus

COMETA 12

GRX110/12

COMETA 18

GRX160/18

COMETA 24

GRX210/24

/

BOX

**OPTIONAL***Optional**Wahlweise**Optionnel***MODELLO / Model**
*Modell / Modél***CODICE / Code**
*Code / Code**Price***ILLUMINAZIONE LED FRONTALE***Frontal led lights system**Frontales led-lichtsystem**Système d'éclairage à del frontale*

L=1100

IG-110

L=1600

IG-160

L=2100

IG-210

90°

IG-90°CMT

**ILLUMINAZIONE LED PLAFONIERA AGGIUNTA***Led lighting canopy**Led-beleuchtung**Lumière d'éclairage de led*

L=1100

IP-110

L=1600

IP-160

L=2100

IP-210

90°

IP-90°CMT

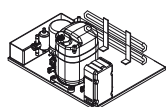
**MAGGIORAZ. CONDENSAZIONI U.C.***Condensing unit**Aufschlag kondensation verflüssigereinheit v.E.**Majoration condensation u.C**Ad acqua/Water*
Mit wasser /À eau

URCAQ

Aria-acqua/Aria-acqua
Luft-Wasser/Air-Eau

URCAQ/AQ

Hydronic system
Hydronic system
Hydronisches System
Système hydronique

HYDP

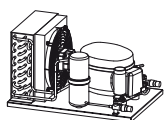
**PREDISPOSIZIONE U.C. EST.***Remote cond. Unit preparation**Vorbereitung externe v.E.**Prédisposition u.C externe*

230 V [**]

PUE

Per la predisposizione all'impianto centralizzato chiedere il preventivo all'ufficio commerciale*To set up the centralized system, ask the sales office for a quote**Um die zentrale Anlage einzurichten, fragen Sie den Verkaufsbüro**Pour mettre en place le système centralisé, demandez un devis au bureau des ventes*

[**] NO per Hydronic System

*NOT available for hydronic systems**NICHT für hydronische Systeme verfügbar**NON disponible pour le système hydronique***60Hz****60HZ***60hz**60hz**60hz*

/

UC60HZ

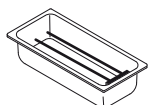
**VASCETTA INOX EVAPORA CONDENSA ELETTRICA***(Electrical) stainless steel condensation container for evaporation**(Elektrisches) kondensbehälter aus rostfreies stahl**(Électrique) bac en acier inoxydable pour l'évaporation de la condensé*

/

VSRC-INOX

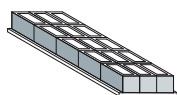
**CONVERSIONE IN PRALINERIA CON CONTROLLO DI UMIDITÀ***Conversion to pralinery with humidity control**Umwandlung in pralinen mit feuchtigkeitskontrolle**Conversion en pralines avec contrôle de l'humidité*

/

MAGG-PRA

**SISTEMA DI CONTROLLO REMOTO***Remote control system**Fernbedienungssystem**Système de commande à distance*

/

RCS



COMETA



CALDO A SECCO
 Dry heat
 Trockene Wärme
 Chaud à sec



+40 / +60
 (°C)

H1220

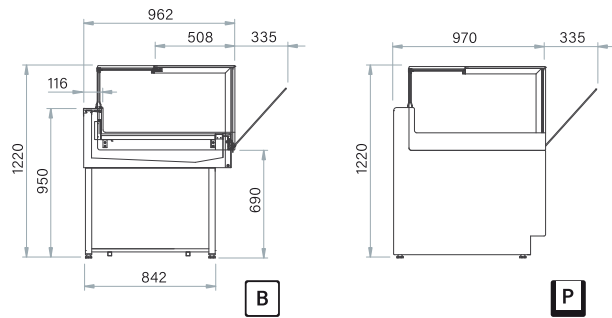

H1380

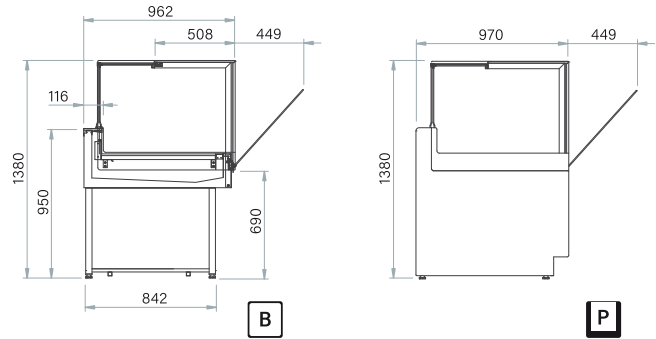

POTENZA COMPRESSORE / POWER COMPRESSOR / PUISSANCE COMPRESSEUR / LEISTUNG VERDICHTER

CS 110	CS 160	CS 210	CS 90° DX	CS 90° SX
--------	--------	--------	-----------	-----------

TENSIONE / Supply / Spannung / Tension

230 V / 1 Ph / 50 Hz

POTENZA ASSORBITA / Electrical power output
 Absorbierte Leistung / Puissance absorbée

0,6 kW	1,2 kW	1,8 kW	1,2 kW	1,2 kW
--------	--------	--------	--------	--------

CS 110

193 kg (H1220)
 203 kg (H1380)

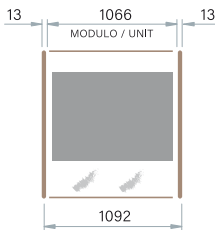

CS 160

263 kg (H1220)
 273 kg (H1380)

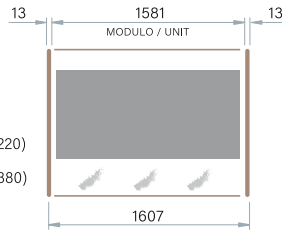

CS 210

315 kg (H1220)
 325 kg (H1380)

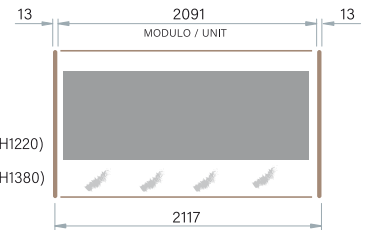

H1220
B CMT110CS-VD-H122-B
P CMT110CS-VD-H122-P

H1220
B CMT160CS-VD-H122-B
P CMT160CS-VD-H122-P

H1220
B CMT210CS-VD-H122-B
P CMT210CS-VD-H122-P

H1380
B CMT110CS-VD-H138-B
P CMT110CS-VD-H138-P

H1380
B CMT160CS-VD-H138-B
P CMT160CS-VD-H138-P

H1380
B CMT210CS-VD-H138-B
P CMT210CS-VD-H138-P

CS 90° DX

263 kg (H1220)
 273 kg (H1380)

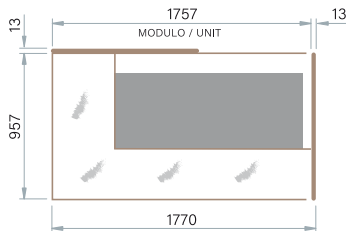

CS 90° SX

263 kg (H1220)
 273 kg (H1380)

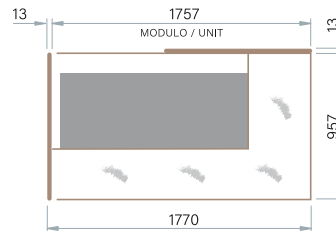

H1220
B CMTDXCS-VD-H122-B
P CMTDXCS-VD-H122-P

H1220
B CMTSXCS-VD-H122-B
P CMTSXCS-VD-H122-P

H1380
B CMTDXCS-VD-H138-B
P CMTDXCS-VD-H138-P

H1380
B CMTSXCS-VD-H138-B
P CMTSXCS-VD-H138-P



CS 110	CS 160	CS 210	CS 90° DX	CS 90° SX
1220 x 1270 x 1560h	1720 x 1270 x 1560h	2260 x 1270 x 1560h	1790 x 1200 x 1550h	1790 x 1200 x 1550h
233 / 243 kg	308 / 318 kg	385 / 395 kg	308 / 320 kg	308 / 320 kg



OPTIONAL

Optional
Wahlweise
Optionnel

MODELLO / Model Modell / Modèl	CODICE / Code Code / Code
/	RPC
/	TPCT
/	RUOTE
/	PIPB
NEUTRO	VDN
L=1100	MII-110
L=1600	MII-160
L=2100	MII-210
90°	MII-90°CMT
[*] Illuminazione NON inclusa / Lighting NOT included / Beleuchtung nicht inb	
L=1100	MCD-110
L=1600	MCD-160
L=2100	MCD-210
90°	MCD-90°CMT
[*] Illuminazione NON inclusa / Lighting NOT included / Beleuchtung nicht inb	
/	BOX
L=1100	IG-110
L=1600	IG-160
L=2100	IG-210
90°	IG-90°CMT
L=1100	IP-110
L=1600	IP-160
L=2100	IP-210
90°	IP-90°CMT
/	RCS

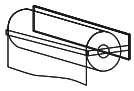

RULLO PORTACARTA

Paper roll holder
Papierträgerrolle
Rouleau porte-papier

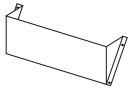

TASCA PORTACARTA

Bag holder/bag holder
Papierträgetasche
Poche porte-papier



KIT RUOTE

Castors kit
Rollen kit
Kit roulettes

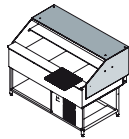

PIANO PORTA BILANCIA INOX

S/s scale-holder countertop addition
Waagträgerebene edelstahl
Plan porte-balance inox



DIVISORIO BASSO IN VETRO

Low glass divider
Tiefer trennelement aus glas
Séparateurs bas en verre

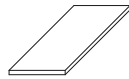

MENSOLA SUPPLEMENTARE

Extra shelf
Extra regal
Plateau extra

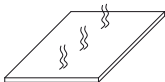

MENSOLA CALDA

Warm shelf
Warm regal
Plateau chaud

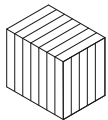

CASSA IN LEGNO PER TRASPORTO

Wooden boxes for transporting
Holzkiste für den transport
Caisse en bois pour transport



ILLUMINAZIONE LED FRONTALE

Frontal led lights system
Frontales led-lichtsystem
Système d'éclairage à del frontale



ILLUMINAZIONE LED PLAFONIERA AGGIUNTA

Led lighting canopy
Led-beleuchtung
Lumière d'éclairage de led



SISTEMA DI CONTROLLO REMOTO

Remote control system
Fernbedienungssystem
Système de commande à distance



H1220

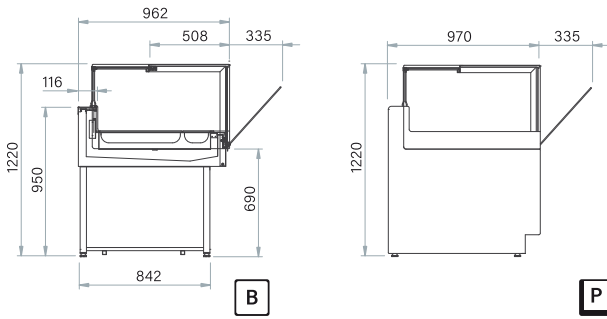

H1380

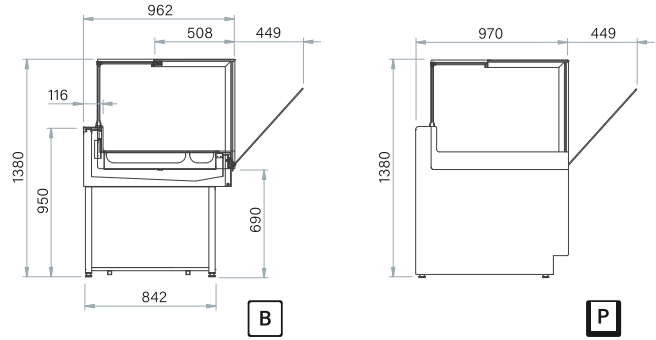

POTENZA COMPRESSORE / POWER COMPRESSOR / PUISSANCE COMPRESSEUR / LEISTUNG VERDICHTER

BM 110	BM 160	BM 210
--------	--------	--------

TENSIONE / Supply / Spannung / Tension

230 V / 1 Ph / 50+ Hz

POTENZA ASSORBITA / Electrical power output
Absorbierte Leistung / Puissance absorbée

1,5 kW	2,4 kW	3 kW
--------	--------	------

BM 110

193 kg (H1220)
203 kg (H1380)

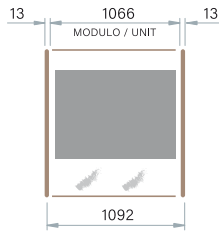

H1220	B	CMT110BM-VD-H122-B
	P	CMT110BM-VD-H122-P
H1380	B	CMT110BM-VD-H138-B
	P	CMT110BM-VD-H138-P

BM 160

263 kg (H1220)
273 kg (H1380)

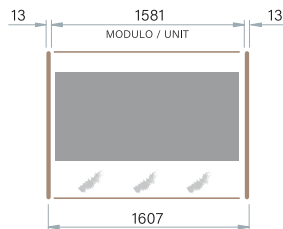

H1220	B	CMT160BM-VD-H122-B
	P	CMT160BM-VD-H122-P
H1380	B	CMT160BM-VD-H138-B
	P	CMT160BM-VD-H138-P

BM 210

315 kg (H1220)
325 kg (H1380)

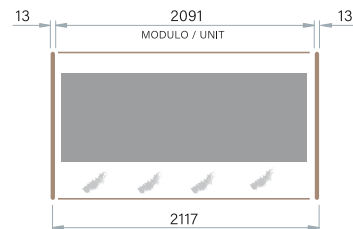

H1220	B	CMT210BM-VD-H122-B
	P	CMT210BM-VD-H122-P
H1380	B	CMT210BM-VD-H138-B
	P	CMT210BM-VD-H138-P

VASCHETTE CONTAINERS SCHALEN CONTENEURS

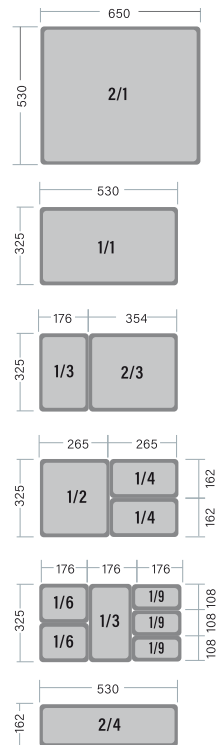

BM 110	BM 160	BM 210
1220 x 1270 x 1560h	1720 x 1270 x 1560h	2260 x 1270 x 1560h
233 / 243 kg	308 / 318 kg	385 / 395 kg



OPTIONAL
Optional
Wahlweise
Optionnel

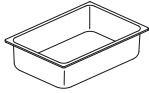

VASCHETTA
Containers
Schalen
Conteneurs

MODELLO / Model
Modell / Modèl

CODICE / Code
Code / Code

530x325	VG1/1-H100
325x265	VG1/2-H100
325x177	VG1/3-H100
265x162	VG1/4-H100
177x162	VG1/6-H100
177x108	VG1/9-H100
350x325	VG2/3-H100
530x325	VG1/1-H65
325x265	VG1/2-H65
325x177	VG1/3-H65
265x162	VG1/4-H65
177x162	VG1/6-H65
177x108	VG1/9-H65
350x325	VG2/3-H65

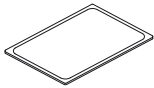

COPERCHIO VASCHETTE
Containers lid
Schalendeckel
Couvercle bac

/	CR1/1
/	CR1/2
/	CR1/3
/	CR1/4
/	CR1/6
/	CR1/9
/	CR2/3

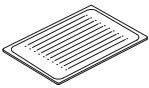

PIANI FORATI
Perforated bases
Gelochte ebenen
Plans perforés

530x325	PF1/1
325x265	PF1/2
325x177	PF1/3
265x162	PF1/4
177x162	PF1/6
325x354	PF2/3
530x650	PF2/1

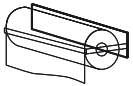

RULLO PORTACARTA
Paper roll holder
Papierträgerrolle
Rouleau porte-papier

/	RPC
---	-----

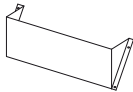

TASCA PORTACARTA
Bag holder/bag holder
Papierträgertasche
Poche porte-papier

/	TPCT
---	------



KIT RUOTE
Castors kit
Rollen kit
Kit roulettes

/	RUOTE	€
---	-------	---

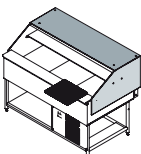

PIANO PORTA BILANCIA INOX
S/s scale-holder countertop addition
Waagträgerebene edelstahl
Plan porte-balance inox

/	PIPB
---	------

**OPTIONAL***Optional**Wahlweise**Optionnel***MODELLO / Model**
*Modell / Modèl***CODICE / Code**
Code / Code**DIVISORIO BASSO IN VETRO***Low glass divider**Tiefer trennelement aus glas**Séparateurs bas en verre*

NEUTRO

VDN

RISCALDATO

VDR

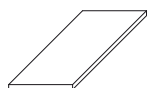
**MENSOLA SUPPLEMENTARE***Extra shelf**Extra regal**Plateau extra*

L=1100

MII-110

L=1600

MII-160

L=2100

MII-210

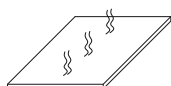
[*] Illuminazione NON inclusa / *Lighting NOT included* / *Beleuchtung nicht inbe***MENSOLA CALDA***Warm shelf**Warm regal**Plateau chaud*

L=1100

MCD-110

L=1600

MCD-160

L=2100

MCD-210

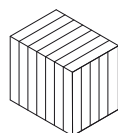
[*] Illuminazione NON inclusa / *Lighting NOT included* / *Beleuchtung nicht inbe***CASSA IN LEGNO PER TRASPORTO***Wooden boxes for transporting**Holzbox für den transport**Caisse en bois pour transport*

/

BOX

**ILLUMINAZIONE LED FRONTALE***Frontal led lights system**Frontales led-lichtsystem**Système d'éclairage à del frontale*

L=1100

IG-110

L=1600

IG-160

L=2100

IG-210

**ILLUMINAZIONE LED PLAFONIERA AGGIUNTA***Led lighting canopy**Led-beleuchtung**Lumière d'éclairage de led*

L=1100

IP-110

L=1600

IP-160

L=2100

IP-210

**SISTEMA DI CONTROLLO REMOTO***Remote control system**Fernbedienungssystem**Système de commande à distance*

/

RCS



EUROPROJET
PROVOCATEUR DE FROID